



Approved baseline and monitoring methodology AM0081

“Flare or vent reduction at coke plants through the conversion of their waste gas into dimethyl ether for use as a fuel”

I. SOURCE, DEFINITIONS AND APPLICABILITY

Sources

This baseline and monitoring methodology is based on the following proposed new methodology:

- NM0265: “Reduction of flaring of COG through conversion into dimethyl ether to be used as fuel in Shanxi, China”, prepared by Mitsubishi UFJ Securities (MUS).

This methodology also refers to the latest approved versions of the following tools:

- Tool to calculate project or leakage CO₂ emissions from fossil fuel combustion;
- Tool to calculate baseline, project and/or leakage emissions from electricity consumption;
- Tool for the demonstration and assessment of additionality.

For more information regarding the proposed new methodologies and the tools as well as their consideration by the Executive Board please refer to <<http://cdm.unfccc.int/goto/MPappmeth>>.

Selected approach from paragraph 48 of the CDM modalities and procedures

“Existing actual or historical emissions, as applicable”

Definitions

For the purpose of this methodology, the following definitions apply:

COG. Coke oven gas, obtained as a by-product of the production of coke in coke production plants.

Delivery Point. The location where DME is delivered to an LPG processing facility(ies), and blended with LPG.

DME. Dimethyl ether (chemical formula: CH₃-O-CH₃), clear colourless environmentally benign and non-toxic compound. It is physically similar to liquefied petroleum gas (LPG) which primarily contains propane and butane.

Applicability

This methodology is applicable to project activities that utilize COG from the existing coke oven plants for the production of DME under the following conditions:

- (1) The methodology is only applicable to newly built DME plants, and not to expansion of existing capacity. The ‘newly built’ DME plants, start the production of DME based on COG input and do not change the DME production process from existing to COG based process;
- (2) COG is the only carbon source used for DME production;



- (3) At the existing facility, all the COG generated in the coke plant was flared or vented, except the COG used in the production process of coke, to atmosphere in the absence of the project activity. This shall be proven by applying one of the following procedures:
 - (a) By **direct measurements** of the amount of COG flared or vented for at least three years prior to the start of the project activity, or as long as the coke plant has been in operation;
 - (b) **Energy** balance of the relevant sections of the coke plant to prove that the COG supplied to the project activity is not used as an energy source before the implementation of the project activity. For the energy balance, the representative process parameters are required. The energy balance must confirm that the COG is not used as an energy source and also provide conservative estimations of the energy content and amount of COG released.
- (4) The coke plant(s) supplying COG to the project activity are able to provide historical data on levels of coal input and/or coke output and produce supporting evidence that flaring or venting was the only means of disposal for surplus COG;
- (5) No other fuel except coal is used in the coke plant;
- (6) The coal used at the coke plant is bituminous coking coal of the same type and specifications both before and after the implementation of the project activity;
- (7) The DME produced will be supplied only to LPG processing facility (ies) for the blending purpose.

Compliance with these applicability conditions must be demonstrated in the PDD, and will be confirmed by the DOE through site visits and checking of documentation during validation/verification, in accordance with the guidance provided in Validation and Verification Manual. However, the following are the possible (and not mandatory) methods to verify the compliance of applicability conditions.

- (1) Applicability conditions (1) and (2) can be confirmed by the DOE by referring to the project feasibility study;
- (2) Applicability condition (3) will need to be met in order to produce a valid PDD and the DOE can confirm the existence of a flaring or venting facility large enough to handle the coke plant's waste COG during the site visit. For competitive reasons, coke plants are not under obligation to make both their coal input and coke output data publicly available (i.e. only make public one set of data or the other). However, the DOE must have access to the all the data for validation purposes;
- (3) Applicability condition (4) can be confirmed in either of the following ways:
 - (a) Project participants will be required to provide a letter formally stating that they do not currently sell any COG to other users; and
 - (b) The DOE will be required to check that facilities such as pipelines or COG liquefaction plants do not exist at the coke plant. This should be a relatively simple process: pipelines carrying COG off-site should be easy to identify, and a liquefaction plant (necessary for inserting COG into tanker trucks or canisters) would be a large operation in itself.
- (4) Applicability condition (5) can be validated based on evidence collected during site visits;
- (5) Applicability condition (6) can be confirmed by demonstrating that the specifications of the coal used by the coke plants during the implementation of the project falls within the

specification ranges identified in historical data or in pre-project activity contractual agreements between the coke plant and their coal supplier(s);

- (6) Applicability condition (7) can be confirmed by the DOE from the monitoring data obtained for the delivery of the DME to a Delivery Point, (as defined in definitions section of the methodology), from which point in the distribution process it can be readily assumed that the DME will be utilised by a nearby consumer. Any DME for which such data is not available will not be counted towards the baseline emissions.

In addition, the applicability conditions included in the tools referred to above apply.

Finally, this methodology is only applicable if the application of the procedure to identify the baseline scenario results in combination of plausible baseline scenarios as per Table 2 of the methodology.

II. BASELINE METHODOLOGY PROCEDURE

Project boundary

The following figure illustrates the **spatial extent** of the project boundary:

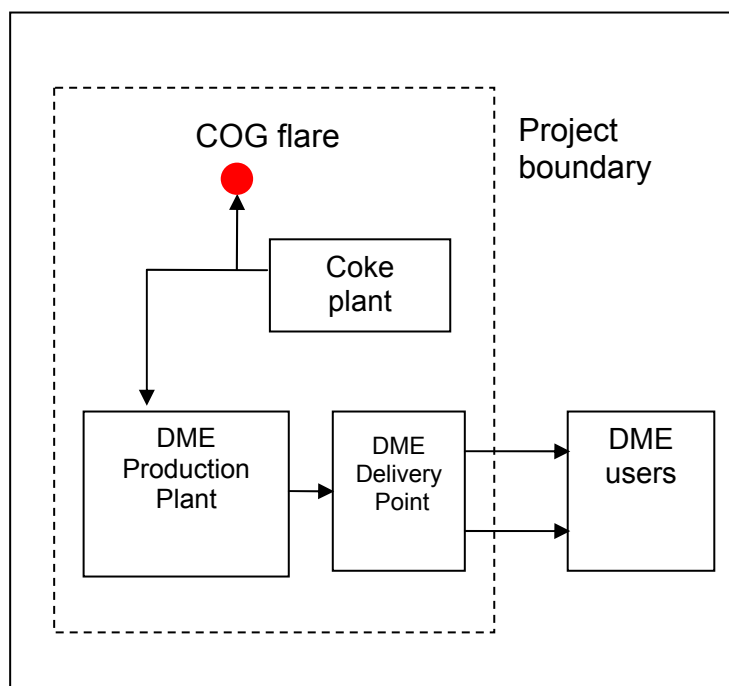

Figure 1: The physical boundary of the project activity

The greenhouse gases included in or excluded from the project boundary are shown in Table 1.



Table 1: Emissions sources included in or excluded from the project boundary

	Source	Gas	Included?	Justification / Explanation
Baseline	Emissions due to coal consumption in the production of coke in coke plant	CO ₂	Yes	Main emission source
		CH ₄	No	Although there can be a small emission of non-combusted CH ₄ from a flare, this is excluded from the baseline for conservativeness
		N ₂ O	No	Excluded for simplification. This is conservative
	Consumption of fossil fuel (Natural gas or propane) by users who switch to DME	CO ₂	Yes	Important source of emissions
		CH ₄	No	Excluded for simplification. This is conservative
		N ₂ O	No	Excluded for simplification. This is conservative
Project Activity	Emissions due to coal consumption (process and fuel) in the in coke plant, in year y	CO ₂	Yes	May be an important emission source
		CH ₄	No	Excluded for simplification. This emission source will be negligible
		N ₂ O	No	Excluded for simplification. This emission source will be negligible
	Emissions due to coal consumption (process and fuel) in the in coke plant	CO ₂	Yes	May be an important emission source
		CH ₄	No	Excluded for simplification. This emission source will be negligible
		N ₂ O	No	Excluded for simplification. This emission source will be negligible
	Emissions due to the transport of auxiliary fossil fuels to the DME production plant	CO ₂	Yes	May be an important emission source
		CH ₄	No	Excluded for simplification. This emission source will be negligible
		N ₂ O	No	Excluded for simplification. This emission source will be negligible
	Emissions due to the transport of DME to the Delivery Point	CO ₂	Yes	May be an important emission source
		CH ₄	No	Excluded for simplification. This emission source will be negligible.
		N ₂ O	No	Excluded for simplification. This emission source will be negligible
	Emission due to consumption of fossil fuel based electricity in the DME production plant	CO ₂	No	Excluded for simplification. This emission source will be negligible
		CH ₄	Yes	May be an important emission source
		N ₂ O	No	Excluded for simplification. This emission source will be negligible
	Emission due to additional consumption of fossil fuel based electricity in the coke plant(s)	CO ₂	Yes	Yes, important source of emissions
		CH ₄	No	Excluded for simplification. This emission source will be negligible
		N ₂ O	No	Excluded for simplification. This emission source will be negligible



	Source	Gas	Included?	Justification / Explanation
	Emission due to COG pipeline leakage	CO ₂	No	Excluded for simplification. This emission source will be negligible
		CH ₄	Yes	Important source of emissions
		N ₂ O	No	Excluded for simplification. This emission source will be negligible

Procedure for the identification of the most plausible baseline scenario and assessment of additionality

The project participants shall apply the following three steps to identify the baseline scenario:

Step 1: List all realistic credible baseline options

Realistic and credible alternatives should be determined for the baseline options. Baseline scenarios for COG treatment/disposal and for baseline fuel consumption are considered separately.

The following minimum list of options for the baseline should be examined to determine the baseline scenario for the COG treatment/disposal and for the baseline fuel consumption.

Scenarios for COG treatment/disposal.

It should be noted that the following scenarios, *inter alia*, will be assessed only in respect to the portion of the total COG which meets the third applicability condition (i.e. is currently being flared or vented and not used for productive purposes within the coke plant).

- COG A: Continued flaring/venting of COG at the coke producing facilities;
- COG B: Recovery, processing and distribution of COG into a fuel/a useful product other than DME (e.g. methanol, ammonia, hydrogen, town gas, SNG);
- COG C: COG used for power generation for other specific users;
- COG D: COG used for power generation to export to the grid;
- COG E: COG used as a thermal energy source by a steel plant or other industrial process;
- COG F: COG used as a feedstock for DME production (the project activity without being registered as a CDM project activity).

Scenarios for baseline fuel consumption include, *inter alia*:

- FUEL A: Biofuel is used;
- FUEL B: Natural gas is used;
- FUEL C: One or more types of fossil fuel with a carbon emission factor equal to or higher than propane¹ are used in the baseline. The fossil fuel(s) should be specified;
- FUEL D: Waste gas derived DME, or other waste derived fuel is used in the baseline;
- FUEL E: DME produced from virgin fossil fuels is used.

¹ The carbon intensity of propane is next only to natural gas, among the commonly used fossil fuels, which is conservative.

When selecting between FUEL B and FUEL C, the following guidance should be applied:

- In the case that the baseline for fuels is a mix of FUEL B and FUEL C, then it should be assumed that FUEL B is the baseline (i.e. consumption of natural gas);
- Further, if natural gas is available (i.e. if a distribution pipeline infrastructure is in place) within 100 km of a Delivery Point (please see below for definition of Delivery Point), then it will be assumed that FUEL B is the baseline.

Step 2: Eliminate options which do not comply with applicable laws and regulations

The options that do not comply with applicable laws and regulations are eliminated by applying Sub-step 1b of the latest version of the “Tool for the demonstration and assessment of additionality”.

Step 3: Eliminate options which face prohibitive investment or other barriers

The project participant shall examine each of the options that were identified in Step 1 excluding the options that do not comply with applicable laws and regulations identified in Step 2 in order to determine the most likely baseline scenario. Step 3 of the latest approved version of the “Tool for the demonstration and assessment of additionality” should be used to eliminate baseline scenarios which are clearly unattractive or associated with prohibitive barriers.

If the two or more alternative baseline scenarios remain, they shall be examined using Step 2 of the “Tool for the demonstration and assessment of additionality”. The most financially or economically attractive option is selected as the baseline scenario. If two or more baseline scenarios are deemed to be equally financially or economically attractive, then the least emissions intensive scenario shall be selected as the baseline.

Data requirements for baseline scenario determination are as stipulated in the relevant steps of the “Tool for the demonstration and assessment of additionality”.

The methodology is only applicable for the following combinations of baseline scenarios:

Table 2: Combination of baseline scenarios for which methodology is applicable

Combination No.	Scenario for COG disposal	Scenario for fuel consumption
1	COG A	FUEL B
2	COG A	FUEL C
3	COG A	Fuel B + Fuel C

The latest version of the “Tool for the demonstration and assessment of additionality” shall be used for the assessment of additionality.

The following additional guidance is offered when applying the “Tool for the demonstration and assessment of additionality”.

Step 1: Identification of alternatives to the project activity consistent with current laws and regulations

Sub-step 1a: Define alternatives to the project activity

The main plausible alternatives are described in the identification of baseline scenario section. The same scenarios are to be considered here for the purpose of determining additionality.

Sub-step 1b: Enforcement of applicable laws and regulations

As explained in the baseline scenario section above, this step is also utilized. No modification or additional guidance for this step is offered.

Step 2: Investment analysis

When conducting investment analysis as per Step 2 in the latest “Tool for the demonstration and assessment of additionality”, the following guidance applies:

- If the COG is to be obtained from more than one coke plant, then the individual arrangements (contracts) with each coke plant should be examined separately;
- Any cost-savings brought about by reduction of flaring/venting at the coke plant should be considered as a revenue source (e.g. lower maintenance costs for flare);
- When calculating the project IRR, the opportunity cost of COG should be counted as zero. Therefore, payments made for COG cannot be counted when carrying out a financial analysis. However, costs incurred for pre-treatment of COG and cost of pipeline to make it ready for use by the DME plant may be counted.

Step 3: Barrier analysis

Use the Step 3 from “Tool for the demonstration and assessment of additionality”.

Step 4: Common practice analysis

Use the Step 4 from “Tool for the demonstration and assessment of additionality”.

Baseline Emissions

The fundamental baseline emissions underlying this methodology are the emissions of the fossil fuel replaced by DME produced from COG. Under this methodology, only emissions associated with the portion of DME which is clearly tracked to a Delivery Point can be counted towards the baseline emissions. The baseline emissions are therefore capped by the amount of the DME delivered to the Delivery Point.² To account for any amount of COG that would not be produced in the baseline scenario (for instance, in the project scenario operating parameters of the coke plant would be selected to increase the COG production per tonne of coal above that in the baseline), all the fossil carbon contained in the coal (process coal and fuel coal) used both in the baseline and project situations, is counted as CO₂ emissions. Although the carbon transferred into the coke is emitted later, as the same level of coke production is assumed in the baseline and project scenarios, these amounts cancel out when calculating the emission reductions.

The baseline emissions are determined using the following formula:

$$BE_y = BL_{\text{coal},y} + BL_{\text{FF},y} \quad (1)$$

² This assumes compliance with Applicability Condition (2), which stipulates that waste COG is the only carbon source used as feedstock for the DME production process.

Where:

- BE_y = Baseline emissions in year y (tCO₂e)
 $BL_{coal,y}$ = Baseline emissions in year y in coke plant form the process of production of coke from coal (tCO₂)
 $BL_{FF,y}$ = The baseline emissions due to combustion of fossil fuel in baseline, which is displaced by DME

Step 1: Calculation of baseline emissions in year y in coke plant form the process of production of coke from coal (tCO₂)

$$BE_{coal,y} = \sum_i Q_{coke,i,y} \times R_{coal:coke,i,hy} \times w_{carbon,coal,i} \times 44/12 \quad (2)$$

Where:

- $BE_{coal,y}$ = Baseline emissions in year y in coke plant form the process of production of coke from coal (tCO₂)
 $Q_{coke,i,y}$ = Production of coke in coke plant i in year y (t)
 $R_{coal:coke,i,hy}$ = Ratio of coal to coke of coke plant i (see below for calculation of this ratio)
 $w_{carbon,coal,i}$ = %Carbon (mass basis) in coal used in coke plant i as input for production of coke
44/12 = Molar ratio for conversion of carbon to CO₂

Step 1.1: Calculation of ratio $R_{coal:coke,i,hy}$

The ratio should be calculated separately for each coke plant supplying COG to the project activity. Use the lowest value of $R_{coke:coal,i,hy}$ of the following two options.

Option 1: Historical data

This should be calculated based on the average performance over the past 3 years, or performance since the plant began operation, whichever is lower

$$R_{coal:coke,i,hy} = \frac{1}{n} \left(\sum_{hy=1}^n \left(\frac{Coal_{i,BL,hy}}{Coke_{i,BL,hy}} \right) \right) \quad (3)$$

Where:

- $R_{coal:coke,i,hy}$ = Mass ratio of coal consumed for production of coke and the amount of coke produced by coke plant i based on the average performance over the past 3 years, or performance since the plant began operation
 $Coal_{i,BL,hy}$ = Amount of coal consumed (process coal + fuel coal) in coke plant i in historical year hy (tonnes)
 $Coke_{i,BL,hy}$ = Amount of coke produced at coke plant i in historical year hy (tonnes)
 n = Number of years for which historical data is required ($n = 3$ or years of operation of plant, whichever is lower)

Option 2: Industry norms

In absence of actual data on coal consumption (i.e. process coal + fuel coal) per unit of coke produced in historical years, the manufacturer’s data for the industrial facility shall be used to estimate the amount of coal (process coal + fuel coal) required per unit of coke produced. This manufacturer’s data should be endorsed by independent qualified/certified external process experts such as a chartered engineer with specific reference to any potential difference between manufacturer’s specifications and actual performance at the coke plant. In case any modification is carried out by the project proponent or in case the manufacturer’s data is not available, an assessment should be carried out by independent qualified/certified external process experts such as a chartered engineer on a conservative quantity of coal (process coal + fuel coal) consumed per unit of coke produced. The value arrived at based on the above sources of data, shall be used to estimate the baseline ratio $R_{\text{coal:coke},i,\text{hy}}$. The documentation of such assessment shall be verified by the validating DOE.

Step 2: Calculation of baseline emissions due to use of fossil fuel, which is displaced by DME ($BL_{FF,y}$)

In Baseline determination, it must be demonstrated that the baseline for fuel consumption is either scenario FUEL B or FUEL C. Then, in the baseline calculation, the DME must be tracked to a Delivery Point, to demonstrate a high level of certainty that it is being combusted. It is necessary to account for differences in the carbon intensity of DME and the baseline fuel as a potential source of leakage emissions.

As per the instructions in the baseline determination section, if the baseline scenario for fuel consumption is identified as FUEL B, then it should be assumed for the purposes of the baseline emission calculation that the DME will displace natural gas and therefore the baseline emissions should be calculated based on combustion of natural gas in the baseline. If the baseline scenario for fuel consumption is identified as FUEL C, then it should be assumed that DME will displace propane which can be the baseline fuel. In cases where the baseline scenario is mix of FUEL B and FUEL C, then the baseline emission calculations should be done based on combustion of natural gas in baseline. Therefore, depending upon the baseline scenario, the baseline emissions are calculated.

$$BL_{FF,y} = \sum_j DME_{deliv,j,y} \times w_{\text{carbon},FF,j} \times \frac{NCV_{DME}}{NCV_{FF,j}} \times \frac{44}{12} \tag{4}$$

Where:

- $DME_{deliv,j,y}$ = Quantity of DME which has been delivered to a Delivery Point and displaces fossil fuel j in year y , and where fuel j will be either natural gas or propane, as per the baseline determination section (tDME)
- NCV_{DME} = Net Calorific Value of DME (GJ/t) [28.4 GJ/t]
- $NCV_{FF,j}$ = Net Calorific Value of displaced fossil fuel j (natural gas or propane) (GJ/t)
- $w_{\text{carbon},FF,j}$ = % carbon content (mass basis) of the displaced fuel j (natural gas or propane)

Project Emissions

Project emissions are determined using the following formula:

$$PE_y = PE_{\text{Coal},y} + PE_{\text{CO}_2,ff,y} + PE_{ff_trans,y} + PE_{DME_trans,y} + PE_{\text{CO}_2,elec_DME,y} + PE_{\text{CO}_2,elec_coke,y} + PE_{\text{CH}_4,pipe,y} \tag{5}$$

Where:

PE_y	=	Total project emissions in year y (tCO ₂ e)
$PE_{Coal,y}$	=	Project emissions due to coal consumption (process and fuel) in the in coke plant, in year y (tCO ₂)
$PE_{CO2,ff,y}$	=	Project emission due to fossil fuel consumption in DME plant in year y (tCO ₂ e)
$PE_{ff_trans,y}$	=	Project emissions due to the transport of auxiliary fossil fuels to the DME production plant in year y (tCO ₂ e)
$PE_{DME,trans,y}$	=	Project emissions due to the transport of DME to the Delivery Point in year y (tCO ₂ e)
$PE_{CO2,elec_DME,y}$	=	Project emissions due to consumption of fossil fuel based electricity in the DME production plant in year y (tCO ₂ e)
$PE_{CO2,elec_coke,y}$	=	Project emissions due to additional consumption of fossil fuel based electricity in the coke plant(s) in year y (tCO ₂ e)
$PE_{CH4,pipe,y}$	=	Project emissions due to COG pipeline leakage in year y (tCO ₂ e)

Project emissions due to coal consumption in the production of coke in coke plant, in year y (tCO₂)

$$PE_{coal,y} = \sum_i Q_{coal,i,y} \times w_{carbon,coal,i,y} \times \frac{44}{12} \quad (6)$$

Where:

$PE_{Coal,y}$	=	Project emissions due to coal consumption in the production of coke in coke plant, in year y (tCO ₂)
$Q_{coal,i,y}$	=	Consumption of coal (process coal + fuel coal) for production of coke in coke plant i in year y (t)
$w_{carbon,coal,i}$	=	%Carbon (mass basis) in coal used in coke plant i as input for production of coke
$44/12$	=	Molar ratio for conversion of carbon to CO ₂

Project emissions from fossil fuel consumption (CO₂)

In case fossil fuels are consumed in DME plant, project emissions ($PE_{CO2,ff,y}$) should be calculated using the latest approved version of the “Tool to calculate project or leakage CO₂ emissions from fossil fuel combustion”. For the purpose of PDD development, project participants may assume the amount of fossil fuel to be combusted in the DME plant.

Project emissions from the transport of auxiliary fossil fuels

Fossil fuels consumed in transporting the auxiliary fossil fuels to the project site should be monitored. Emissions from this fossil fuel can be calculated by either of the following approaches:

Option 1: Recording of the actual amount of fuel consumed

$$PE_{ff_trans,y} = \sum_i (Q_{ff_trans,i,y} \times NCV_i \times EF_{ff,i} / 1000) \quad (7)$$

Where:

$Q_{ff_trans,i,y}$	=	Mass or volume of each fossil fuel i consumed in the transportation of auxiliary fossil fuels in year y (t or Nm ³)
NCV_i	=	Net calorific value per mass or volume unit of fuel i (GJ/t or Nm ³)
$EF_{ff,i}$	=	Carbon emissions factor per unit of energy of the fuel i (tCO ₂ /TJ)

For the purpose of PDD development project participants may assume the amount of fossil fuel to be combusted from this source.

Option 2: Recording of the distance travelled and standard assumptions regarding fuel consumption

Alternatively, if the travel distance is monitored instead of fuel consumption, emissions from this source can be calculated as follows:

$$PE_{ff_trans,y} = \sum_v N_{ff,v,y} \times AVD_{ff,v,y} \times EF_{km,v,y} \quad (8)$$

Where:

- $N_{ff,v,y}$ = Number of round trips made using vehicle type v during year y (number/year)
 $AVD_{ff,v,y}$ = Average round trip distance from the point of production to the project activity travelled by vehicle type v , in year y (km)
 $EF_{km,v,y}$ = CO₂ emission factor of vehicle type v (tCO₂/km). A conservative emission factor should be selected from a recognised source of vehicle emission data

For the purpose of PDD production, project participants may assume the distance to the delivery point and the type of vehicle used.

If the delivery of fossil fuel is achieved using vehicles powered by the DME produced by the project, then the number of shipments made and the distance to each Delivery Point should still be recorded, for transparency. However, the emission factor of DME used in this way can be counted as 'zero'. Note that any DME used in this way will not be counted towards baseline emissions. Baseline emissions are calculated based on DME actually delivered to a Delivery Point, therefore DME_{deliv} will be net of any in-house DME consumption.

Project emissions from the transport of DME to the Delivery Point(s)

Fossil fuels consumed in the transporting of the DME to the Delivery Point should be monitored. Emissions from this fossil fuel can be calculated by either of the following approaches:

Option 1: Recording of the actual amount of fuel consumed

$$PE_{DME_trans,y} = \sum_i (Q_{DME_trans,i,y} \times NCV_i \times EF_{ff,i} / 1000) \quad (9)$$

Where:

- $Q_{DME_trans,i,y}$ = Mass or volume of each fossil fuel i consumed in the transportation of DME in year y (t or Nm³)
 NCV_i = Net calorific value per mass or volume unit of fuel i (GJ/t or Nm³)
 $EF_{ff,i}$ = Carbon emissions factor per unit of energy of the fuel i (tCO₂/TJ)

For the purpose of PDD development, project participants may assume the amount of fossil fuel to be combusted from this source.

Option 2: Recording of the distance travelled and standard assumptions regarding fuel consumption

Alternatively, if the travel distance is monitored instead of fuel consumption, emissions from this source can be calculated as follows:

$$PE_{DME_trans,y} = \sum_v N_{DME,v,y} \times AVD_{DME,v,y} \times EF_{km,v,y} \quad (10)$$

Where:

- $N_{DME,v,y}$ = Number of round trips made using vehicle type v during year y (number/year)
 $AVD_{DME,v,y}$ = Average round trip distance from the DME production facility to the Delivery Point travelled by vehicle type v , in year y (km)
 $EF_{km,v,y}$ = CO₂ emission factor of vehicle type v (tCO₂/km). A conservative emission factor should be selected from a recognised source of vehicle emission data

For the purpose of PDD development, project participants may assume the distance to the delivery point and the type of vehicle used.

If the delivery of DME is achieved using vehicles powered by the DME produced by the project, then the number of shipments made and the distance to each Delivery Point should still be recorded, for transparency. However, the emission factor of DME used in this way can be counted as ‘zero’. Note that any DME used in this way will not be counted towards baseline emissions. Baseline emissions are calculated based on DME actually delivered to a Delivery Point, therefore DME_{deliv} will be net of any in-house DME consumption.

Project emissions from electricity consumption at the DME production facility (CO₂)

Project emissions from consumption of additional electricity by the project, $PE_{CO_2,elec_DME,y}$, are determined as per the latest approved version of the “Tool to calculate baseline, project and/or leakage emissions from electricity consumption”.

If electricity is generated on-site from waste gas/ heat from the DME production process, then that portion of the electricity does not need to be counted towards project emissions. In such cases, the electricity produced should be calculated as captive electricity. The emission factor for the portion of electricity generated from waste gas or waste heat may be counted as zero.³

Project emissions from additional electricity consumption at the coke plant(s) (CO₂)

The coke plant(s) supplying COG to the project activity may face a significant increase in electricity consumption, due to the compression of COG prior to sending it to the DME plant through a pipeline.

Additional project emissions from electricity consumption in individual coke plants are calculated by using the latest version of EB approved tool “Tool to calculate baseline, project and/or leakage emissions from electricity consumption”.

³ This only applies where a boiler is run purely on the waste heat/gas and where the output of waste gas/heat based boiler is clearly measurable. In cases where the waste heat/gas is co-fired with a fossil fuel, or waste gas/heat based output is not clearly measurable, project participants should request a revision to this methodology.



To enable the DOE to determine that new project emissions from this source are being accurately monitored, project participants should provide electrical flow diagrams to clearly show:

- (1) The layout of main electricity consuming equipment in the baseline;
- (2) Additional equipment installed specifically for use in the project;
- (3) The location of any pre-existing items of equipment whose load will increase significantly due to the project.

The electricity consumption for new equipment installed as part of the project activity should be included in the project emission calculation. Any increase in electricity consumption as a result of the project activity for existing equipment should be counted towards project emissions. Therefore, both new equipment and existing equipment with significant increased electricity consumption should have electricity meters fitted, and the total power consumption recorded by these meters should be counted towards project emissions.

Project emissions from COG pipeline leakage (CH₄)

Project emissions from this source are to be calculated in the same manner as described in AM0037, Project Emissions.

Project Participants may ignore this emission source if the pipeline that transports the COG to the DME production facility is identical (in terms of length, design, and other characteristics likely to affect fugitive emissions and energy demands for compressors) to the pipeline used to transport the COG to the flare/vent in the baseline scenario, or if fugitive CH₄ emissions can clearly be expected to be lower in the project case.

If transport of the COG to the DME production facility only requires an extension of the pipeline to the flare/vent in the baseline scenario, then baseline emissions along the existing pipeline can be ignored and project emissions only need to be estimated for the pipeline extension.

Calculations:

Emission factors are taken from the 1995 Protocol for Equipment Leak Emission Estimates, published by US EPA.⁴ Emissions should be determined for all relevant activities and all equipment (such as valves, pump seals, connectors, flanges, open-ended lines, etc.).

The US EPA approach is based on average emission factors for total organic compounds (TOC). Methane emissions are calculated by multiplying the methane fraction in the COG with the appropriate emission factors from Table 3 and then summing across all pieces of equipment, as follows:

$$PE_{CH_4, pipeline, y} = GWP_{CH_4} \times w_{CH_4, y} \times \sum_{equipment} [EF_{equipment} \times t_{equipment}] \quad (11)$$

⁴ Please refer to Document reference EPA-453/R-95-017 at <<http://www.epa.gov/ttn/chief/efdocs/equiplks.pdf>>.

Where

- $PE_{CH_4, pipeline, y}$ = Fugitive CH₄ emissions from transportation of the COG to the project activity in year *y* (tCO₂e/yr)
- GWP_{CH_4} = Global Warming Potential for methane
- $w_{CH_4, y}$ = Average mass fraction of methane in the COG in year *y* (t CH₄/t COG)
- $EF_{equipment}$ = The emission factor for the relevant equipment type, taken from Table 3 below, or the 2006 IPCC Guidelines (kg CH₄ / hour / equipment)
- $t_{equipment}$ = The operation time of the equipment (hours)

All data for gas volumes in all equations should be converted to common standard temperature and pressure values. The default density for methane at 0 degrees Celsius and 1 atm is 0.0007168 tCH₄/m³.

It is recommended to group the equipment according to the different types listed in the following table:

Table 3: Oil and natural gas production average emission factors

Equipment type	Service	Emission factor (kg/hour/equipment item) For TOC
Valves	Gas	4.5E-03
Pump seals	Gas	2.4E-03
Others *	Gas	8.8E-03
Connectors	Gas	2.0E-04
Flanges	Gas	3.9E-04
Open-ended lines	Gas	2.0E-03

TOC: Total Organic Compounds

Source: US EPA-453/R-95-017 Table 2.4, page 2-15

* “Other” equipment type was derived from compressors, diaphragms, drains, dump arms, hatches, instruments, meters, pressure relief valves, polished rods, relief valves and vents. This “other” equipment type should be applied for any equipment type other than connectors, flanges, open-ended lines, pumps or valves.

In addition, in case of accidents, the relevant fugitive CH₄ emissions should be calculated. When an accident causes gas leakage from the pipeline, the gas volume is calculated as the sum of (1) the total amount of gas flow from the time the accident occurred until gas flow was shut off, and (2) the total amount of gas remaining in the pipeline at time of shut off. Accidental release of methane from the pipeline should be calculated as:

$$EFA_y = GWP_{CH_4} \times \frac{1}{1000} (V_{accident} + V_{remain, accident}) \times w_{CH_4, pipeline, accident} \tag{12}$$

With

$$V_{accident} = t_{accident} \times F = (t_2 - t_1) \times F \tag{13}$$

and

$$V_{remain,accident} = d^2 \times \pi \times L \times \frac{P_p}{P_s} \times \frac{T_s}{T_p} \times \frac{V_{d,accident}}{\sum_i V_{Xi,d,accident} + V_{d,accident}} \quad (14)$$

Where

- EFA_y = Methane emissions from the transport pipeline due to an accidental event (t CO₂-e)
- $V_{accident}$ = The volume of COG supplied to the pipeline from the coke plant from the time the gas leakage started until the shutdown valves were closed (m³)
- $V_{remain,accident}$ = The volume of COG remaining in the pipeline after the shutdown valves have been closed (m³)
- $W_{CH4, pipeline, accident}$ = The fraction of methane in the COG on a mass basis (kg CH₄/m³)
- $t_{accident}$ = Duration of accident (Sec)
- $t1$ = The time the gas leakage caused by the accident occurred (time in sec during the hour of incident occurred)
- $t2$ = The time that the shutdown valves closed both the upstream and downstream pipeline (time in sec during the hour when the pipe was shut)
- F = The flow rate of COG supplied from the coke plant (m³/sec)
- d = The radius of the pipeline (meters)
- π = The ratio of the circumference of a circle to its diameter (unitless)
- L = The length of the pipeline (meters)
- P_p = The pressure in the pipeline when the shutdown valves close both the upstream and downstream of the pipeline (atm)
- P_s = Standard pressure (atm)
- T_p = The temperature in the pipeline when the shutdown valves close both the upstream and downstream of the pipeline (°C)
- T_s = Standard temperature (°K)
- $V_{d,accident}$ = The volume of COG supplied to the pipeline from the coke plant before the accident occurs during the period (m³)
- $V_{Xi,d,accident}$ = The volume of gas supplied to the pipeline from other sources, if any, before the accident occurs during the period (m³)

Leakage

No leakage emissions identified for the purpose of this methodology.

Emission Reductions

Emission reductions are calculated as follows: Emission reductions are calculated as the difference between baseline and project emissions, taking into account any adjustments for leakage:

$$ER_y = BE_y - (PE_y + LE_y) \quad (15)$$

Where:

- ER_y = Emission reductions in year y (tCO₂e)
- BE_y = Baseline emissions in year y (tCO₂e)
- PE_y = Project emissions in year y (tCO₂e)
- LE_y = Leakage emissions in year y (tCO₂e)

**Changes required for methodology implementation in 2nd and 3rd crediting periods**

The changes in the CDM-PDD for 2nd and 3rd crediting period should be carried out in accordance with the “Procedures for renewal of the crediting period of a registered CDM project activity” approved by CDM Executive Board.

Data and parameters not monitored

In addition to the parameters listed in the tables below, the provisions on data and parameters not monitored in the tools referred to in this methodology apply.

ID Number:	1
Parameter:	$R_{Coal:coke,i,hy}$
Data unit:	Fraction (t Coal/t Coke)
Description:	Mass ratio of coal consumed for production of coke and the amount of coke produced by coke plant i based on the average performance over the past 3 years, or performance since the plant began operation
Source of data:	Calculated based on lower value of 1) historical data (based on the average performance over the past 3 years, or performance since the plant began operation, whichever is lower); and 2) industry norm
Measurement procedures (if any):	N/A
Any comment:	

ID Number:	2
Parameter:	$Coal_{i,BL,hy}$
Data unit:	tonnes
Description:	Amount of coal consumed (process coal + fuel coal) in coke plant i in historical year hy (tonnes)
Source of data:	Plant historic records
Measurement procedures (if any):	Plant mass balance methods
Any comment:	

ID Number:	3
Parameter:	$Coke_{i,BL,hy}$
Data unit:	Tonnes
Description:	Amount of coke produced at coke plant i in historical year hy (tonnes)
Source of data:	Plant historic records
Measurement procedures (if any):	Plant mass balance methods
Any comment:	



ID Number:	4
Parameter:	$W_{\text{carbon,coal},i}$
Data unit:	%
Description:	% Carbon (mass basis) in coal used in coke plant i as input for production of coke
Source of data:	Actual measurements, official local or regional data
Measurement procedures (if any):	If measured, standard procedures should be followed
Any comment:	Actual measurements, if available, will be preferred to official data. If official data is used, regional or national data for exact grade of coal should be used. If only a range of data for carbon content of coal is available, use the lowest value

ID Number:	5
Parameter:	$W_{\text{carbon,FF}}$
Data unit:	%
Description:	% Carbon content (mass basis) of the displaced fuel j (natural gas or propane)
Source of data:	Actual measurements, official local or regional data
Measurement procedures (if any):	If measured, standard procedures for measuring NCV should be followed
Any comment:	Actual measurements, if available, will be preferred to official data. If official data is used, local data will be preferred to regional or national data

ID Number:	6
Parameter:	$EF_{km,v,y}$
Data unit:	kg CO ₂ /km
Description:	CO ₂ emission factor of vehicle type v
Source of data:	Actual measurements, official local or regional data, IPCC defaults.
Measurement procedures (if any):	Project participants should obtain actual measured data where possible. If this is not possible, then official local or regional data should be used. IPCC defaults can be used in the absence of local/regional data A conservative emission factor should be selected from a recognized source of vehicle emission data. A default value of 1.097 kgCO ₂ /km is provided, based on the US EPA's figure for pre-1972 diesel trucks
Any comment:	If IPCC defaults are to be used, project participants must demonstrate that they reflect conservatively the actual emission factor of the fleet of vehicles used

ID Number:	7
Parameter:	GWP_{CH_4}
Data unit:	tCO ₂ e/tCH ₄
Description:	Global warming potential for methane for the relevant commitment period
Source of data:	Standard figure in UNFCCC guidelines and IPCC literature
Measurement procedures (if any):	N/A
Any comment:	



ID Number:	8
Parameter:	NCV_{DME}
Data unit:	GJ/t
Description:	The net calorific value (LHV) of DME
Source of data:	Actual measurements, official local or regional data
Measurement procedures (if any):	N/A
Any comment:	DME has a fixed molecular structure (CH_3OCH_3), therefore any measurements of the NCV of pure DME should produce very similar values

ID Number:	9
Parameter:	NCV_{FF}
Data unit:	GJ/t
Description:	The net calorific value (LHV) of displaced fossil fuel
Source of data:	Actual measurements, official local or regional data
Measurement procedures (if any):	If measured, standard procedures for measuring NCV should be followed
Any comment:	Actual measurements, if available, will be preferred to official data. If official data is used, local data will be preferred to regional or national data

ID Number:	10
Parameter:	$EF_{equipment}$
Data unit:	kgCH ₄ /hour
Description:	Emissions factor for each equipment type
Source of data:	2006 IPCC Guidelines
Measurement procedures (if any):	n/a
Any comment:	

ID Number:	11
Parameter:	d and L
Data unit:	M
Description:	d : radius of the pipeline used in the project activity L : length of the pipeline used in the project activity
Source of data:	Pipeline schematics, or audit of pertinent sections of the pipeline
Measurement procedures (if any):	Can be measured in conjunction with equipment counts
Any comment:	Used for estimating accidental fugitive emissions from the pipeline transporting COG

III. MONITORING METHODOLOGY

Project participants will be required to monitor the following items in order to complete emission reduction calculations:

- The type and amount of each coking coal used in each coking plant during the crediting period;
- Amount of coal consumption (process and fuel) in each coking plant during the crediting period;
- The quantity of fossil fuels combusted as a result of the project activity (i.e. in the operation of the DME production facility or power plant);
- The quantity and carbon intensity of electricity imported to the project activity;
- The carbon emissions from the transport of auxiliary fuel to the project activity;
- The amount of electricity imported by the project activity from a grid and/or captive power generation facility, separately for the coke plant(s) and the DME production facility;
- The carbon emission factor of each grid and captive power plants supplying power to the project activity.

In addition, the monitoring provisions in the tools referred to in this methodology apply.

Data and parameters monitored

The following data and parameters are monitored as part of this methodology.

Data / Parameter:	$DME_{deliv,y}$
Data unit:	Tonnes
Description:	Amount of DME delivered to a Delivery Point j in year y
Source of data:	Actual transportation records
Measurement procedures (if any):	The amount of DME delivered to the LPG processing facility(ies) will be recorded on an ongoing basis, aggregated monthly
Monitoring frequency:	Monthly
QA/QC procedures:	Sales receipts and transport records to be made available to the DOE for verification. In addition, the LPG processing facility's records of the blending process should be checked to ensure that DME delivered is being blended with LPG for distribution
Any comment:	(a) This figure should be cross-checked with DME sales figures, to ensure that the amount of DME sold to the distributor is not greater than the amount produced by the Project

Data / Parameter:	$Q_{coal,i,y}$
Data unit:	Tonnes
Description:	Consumption of coal (process coal + fuel coal) for production of coke in coke plant i in year y (t)
Source of data:	Measured
Measurement procedures (if any):	The amount of coal consumed by the coke plant should be recorded
Monitoring frequency:	The monitoring record should be updated monthly
QA/QC procedures:	Coal input will be a key factor in the operation of a coke plant. Any major changes in the amount of coal input should be justified in the monitoring report
Any comment:	



Data / Parameter:	$Q_{\text{coke},i,y}$
Data unit:	Tonnes
Description:	Production of coke in coke plant i in year y (t)
Source of data:	Measured
Measurement procedures (if any):	The amount of coke produced by the coke plant should be recorded
Monitoring frequency:	The monitoring record should be updated monthly
QA/QC procedures:	Coke output will be a key factor in the operation of a coke plant. Any major changes in the amount of coke output should be justified in the monitoring report
Any comment:	

Data / Parameter:	$W_{\text{carbon,coal},i,y}$
Data unit:	%
Description:	% Carbon (mass basis) in coal used in coke plant i as input for production of coke, in year y
Source of data:	Actual measurements, official local or regional data
Measurement procedures (if any):	If measured, standard procedures should be followed
Monitoring frequency:	The monitoring record should be updated monthly
QA/QC procedures:	Coal input will be a key factor in the operation of a coke plant. Since it is required that the coal used in the project should be same as in baseline, any major changes in the % C of coal input should be justified in the monitoring report
Any comment:	Actual measurements, if available, will be preferred to official data. If official data is used, regional or national data for exact grade of coal should be used. If only a range of data for carbon content of coal is available, use the highest value

Data / Parameter:	$Q_{\text{ff trans},i,y}$
Data unit:	t/yr or Nm ³ /yr
Description:	Mass or volume of each fossil fuel i consumed in the transportation of auxiliary fossil fuels in year y
Source of data:	Measured
Measurement procedures (if any):	A record will be kept of fuel consumed in the delivery of auxiliary fossil fuels to the project activity
Monitoring frequency:	Continuous
QA/QC procedures:	The record of fuel consumption can be crosschecked against the measured distance between the auxiliary fossil fuel source and the project site, and the type of vehicle known to be used for the transport
Any comment:	



Data / Parameter:	NCV _{DME} and NCV _{FF}	
Data unit:	(GJ/t or Nm ³); and (GJ/t)	
Description:	Net Calorific Value of DME and Net Calorific Value of displaced fossil fuel <i>j</i> (natural gas or propane)	
Source of data:	The Net Calorific value of 28.4 GJ/t can be used for DME. For Natural Gas or Propane, the following data sources may be used if the relevant conditions apply:	
	Data source	Conditions for using the data source
	a) Values provided by the fuel supplier in invoices;	This is the preferred source
	b) Measurements by the project participants;	If a) is not available.
	c) Regional or national default values;	If a) is not available These sources can only be used for liquid fuels and should be based on well-documented, reliable sources (such as national energy balances)
d) IPCC default values at the lower limit of the uncertainty at a 95% confidence interval as provided in table 1.4 of Chapter 1 of Vol.2 (Energy) of 2006 IPCC Guidelines on National GHG Inventories.	If a) is not available	
Measurement procedures (if any):	For a) and b): Measurements should be undertaken in line with national or international standards For a): If the fuel supplier does provide the NCV value and the CO ₂ emissions factor on the invoice and these two values are based on measurements for this specific fuel, the CO ₂ factor should be used. If Option a) is not available then Options b), c) or d) should be used	
Any comment:		



Data / Parameter:	NCV _i and EF _{ff,i}	
Data unit:	(TJ/t or Nm ³); and (tCO ₂ /TJ)	
Description:	Net calorific value per mass or volume unit of fuel <i>i</i> , and Carbon emissions factor per unit of energy of the fuel <i>i</i>	
Source of data:	The following data sources may be used if the relevant conditions apply:	
	Data source	Conditions for using the data source
	a) Values provided by the fuel supplier in invoices;	This is the preferred source
	b) Measurements by the project participants;	If a) is not available.
	c) Regional or national default values;	If a) is not available These sources can only be used for liquid fuels and should be based on well-documented, reliable sources (such as national energy balances)
d) IPCC default values at the lower limit of the uncertainty at a 95% confidence interval as provided in table 1.4 of Chapter 1 of Vol.2 (Energy) of 2006 IPCC Guidelines on National GHG Inventories.	If a) is not available	
Measurement procedures (if any):	For a) and b): Measurements should be undertaken in line with national or international standards For a): If the fuel supplier does provide the NCV value and the CO ₂ emissions factor on the invoice and these two values are based on measurements for this specific fuel, the CO ₂ factor should be used. If Option a) is not available then Options b), c) or d) should be used	
Any comment:		

Data / Parameter:	$Q_{DME\ trans, i, y}$
Data unit:	t/yr or Nm ³ /yr
Description:	Mass or volume of each fossil fuel <i>i</i> consumed in the transportation of DME in year <i>y</i>
Source of data:	Measured
Measurement procedures (if any):	A record will be kept of fuel consumed in the delivery of DME to the Delivery Point(s)
Monitoring frequency:	Continuous
QA/QC procedures:	The record of fuel consumption can be crosschecked against the measured distance between the DME production facility and the Delivery Point, and the type of vehicle known to be used for the transport
Any comment:	



Data / Parameter:	$N_{ff,v,y}$
Data unit:	round trip/yr
Description:	Number of round trips made using vehicle type v during year y
Source of data:	Counted
Measurement procedures (if any):	Each delivery of auxiliary fossil fuel will be logged on arrival at the DME plant
Monitoring frequency:	Continuous
QA/QC procedures:	Monitored data can be crosschecked against receipts from the transport company
Any comment:	

Data / Parameter:	$N_{DME,v,y}$
Data unit:	round trip/yr
Description:	Number of round trips made using vehicle type v during year y
Source of data:	Counted
Measurement procedures (if any):	Each delivery of DME will be logged on departure from the DME plant
Monitoring frequency:	Continuous
QA/QC procedures:	Monitored data can be crosschecked against receipts from the transport company
Any comment:	

Data / Parameter:	$AVD_{ff,v,y}$
Data unit:	km/round trip
Description:	Average round trip distance from the point of production of the project activity traveled by vehicle type v , in year y
Source of data:	Measured
Measurement procedures (if any):	Distance can be measured on a map
Monitoring frequency:	Annual
QA/QC procedures:	Validator/verifier may wish to double-check the distance by driving between the various locations
Any comment:	

Data / Parameter:	$AVD_{DME,v,y}$
Data unit:	km/round trip
Description:	Average round trip distance from the DME production facility to the Delivery Point traveled by vehicle type v , in year y
Source of data:	Measured
Measurement procedures (if any):	Distance can be measured on a map
Monitoring frequency:	Annual
QA/QC procedures:	Validator/verifier may wish to cross-check the distance through other sources
Any comment:	



Data / Parameter:	$t_{equipment}$
Data unit:	Hours
Description:	Operation time of the pipeline equipment
Source of data:	Actual measurements
Measurement procedures (if any):	Recorded monthly, aggregated annually
Monitoring frequency:	Continuously
QA/QC procedures:	
Any comment:	

Data / Parameter:	$V_{accident}$
Data unit:	m^3
Description:	The volume of COG supplied to the pipeline from the coke plant from the time the gas leakage started until the shutdown valves were closed
Source of data:	Orifice meter
Measurement procedures (if any):	Reading of meter by operational staff and recording into log and database
Monitoring frequency:	Continuously
QA/QC procedures:	Consistency of check of measurements with commercial data (cf. AM0009)
Any comment:	

Data / Parameter:	$V_{remain,accident}$
Data unit:	m^3
Description:	The volume of COG remaining in the pipeline after the shutdown valves have been closed
Source of data:	Orifice meter
Measurement procedures (if any):	Reading of meter by operational staff and recording into log and database
Monitoring frequency:	Continuously
QA/QC procedures:	Consistency of check of measurements with commercial data (cf. AM0009)
Any comment:	

Data / Parameter:	t_1 and t_2
Data unit:	Sec
Description:	t_1 : Time the gas leakage caused by the accident occurred. t_2 : Time that the shutdown valves closed both the upstream and downstream pipeline
Source of data:	Plant records
Measurement procedures (if any):	None
Monitoring frequency:	Once per event
QA/QC procedures:	None
Any comment:	None



Data / Parameter:	F
Data unit:	m ³ /sec
Description:	Flow rate of COG supplied from the coke plant
Source of data:	Flow meter data
Measurement procedures (if any):	Data should be measured using accurate and calibrated flow meters. Measurements should be taken at the point that COG enters the pipeline for transport to the flare/vent (in the baseline scenario) or enters the pipeline for transport to the DME plant (in the case of the project scenario). Data can be collected in conjunction with V _y
Monitoring frequency:	Continuous
QA/QC procedures:	Volume of gas should be completely metered with regular calibration of equipment
Any comment:	

Data / Parameter:	T _p
Data unit:	°C
Description:	The temperature in the pipeline when the shutdown valves close both the upstream and downstream of the pipeline
Source of data:	Temperature meter
Measurement procedures (if any):	Reading of meter by operational staff and recording into log and database
Monitoring frequency:	When an accident causes COG leakage from a pipeline, the COG leakage volume is less than the sum of (1) the total amount of gas that flowed during the time the accident occurred until the gas flow is shut and (2) the total amount of gas remaining in the pipeline. Therefore, the temperature of the gas in the pipeline needs to be measured only when the shutdown valves close
QA/QC procedures:	Consistency checks of measurement with operation data (cf. AM0009)
Any comment:	

Data / Parameter:	P _p
Data unit:	Atm
Description:	P _p is the pressure in the pipeline when the shutdown valves close both the upstream and downstream of the pipeline
Source of data:	Pressure meter
Measurement procedures (if any):	Reading of meter by operational staff and recording into log and database
Monitoring frequency:	Continuously
QA/QC procedures:	Consistency checks of measurement with operation data (cf. AM0009)
Any comment:	



Data / Parameter:	$V_{d,accident}$
Data unit:	m^3
Description:	The volume of COG supplied to the pipeline from the coke plant before the accident occurs during the period day
Source of data:	Orifice meter
Measurement procedures (if any):	Reading of meter by operational staff and recording into log and database
Monitoring frequency:	Continuously
QA/QC procedures:	Consistency checks of measurement with operation data (cf. AM0009)
Any comment:	

Data / Parameter:	$V_{X_i,d,accident}$
Data unit:	m^3
Description:	The volume of gas supplied to the pipeline from other sources, if any, before the accident occurs during the period day
Source of data:	Orifice meter
Measurement procedures (if any):	
Monitoring frequency:	Continuously
QA/QC procedures:	Consistency checks of measurement with operation data (cf. AM0009)
Any comment:	

IV. REFERENCES AND ANY OTHER INFORMATION

Not applicable.

History of the document

Version	Date	Nature of revision(s)
01	EB 47, Annex 3 28 May 2009	Initial adoption.