



Approved baseline and monitoring methodology AM0058

“Introduction of a new primary district heating system”

I. SOURCE AND APPLICABILITY

Source

This methodology is based on the proposed new methodology NM0181-rev “Houma District Heating project, Shanxi Province, P.R.C.”, prepared by COWI A/S, Energy Department, Denmark.

This consolidated baseline and monitoring methodology is based on elements from the following approved baseline and monitoring methodologies:

- ACM0011 “Consolidated baseline methodology for fuel switching from coal and/or petroleum fuels to natural gas in existing power plants for electricity generation”;
- AM0029 “Methodology for Grid Connected Electricity Generation Plants using Natural Gas”;
- AM0044 “Energy efficiency improvement projects: boiler rehabilitation or replacement in industrial and district heating sector”.

The methodology also refers to the latest approved version of the following tools:

- “Combined tool to identify the baseline scenario and demonstrate additionality”;
- “Tool for the demonstration and assessment of additionality”;
- “Tool to calculate the emission factor for an electricity system”;
- “Tool to calculate project or leakage CO₂ emissions from fossil fuel combustion”.

For more information regarding the proposed new methodology, approved methodologies and the tools as well as their consideration by the Executive Board please refer to <http://cdm.unfccc.int/goto/MPappmeth>.

Selected approach from paragraph 48 of the CDM modalities and procedures

“Emissions from a technology that represents an economically attractive course of action, taking into account barriers to investment”

Definitions

Building. A heat consumer that is either a residential/commercial user.

Existing buildings/sub-area. Buildings in a part of the area supplied by a sub-station, during the project activity, that were connected to an existing isolated heat distribution network (i.e. to an existing a boiler house) before the start of the project activity. Recently constructed buildings (i.e. built after the start of the project activity either next to existing buildings or in place of a demolished building) that are connected to sub-stations that, as a result of the project activity, replace old boiler houses, supplying to existing isolated heat distribution network, should be treated as existing buildings.



New buildings/sub-area.¹ Buildings in a part of the area supplied by a sub-station, during the project activity, that are constructed after the start of the implementation of the project activity. These are buildings constructed in an area which prior to project activity did not have any heat distribution network. .

Applicability

The methodology is applicable to project activities that introduce a new primary district heating system to supply heat to residential and commercial consumers, where the heat comes:

- (1) Predominantly from an existing grid connected power plant with no heat extraction, other than the required for the operation of the power plant auxiliary systems, prior to the project activity. cogeneration plant (CHP) The project may also involve introduction of new modern heat only boilers² to supplement heat from CHP the existing power plant; or
- (2) From heat only boiler(s), in which case the project boundary includes only existing buildings.

The methodology is applicable under the following conditions:

- (1) The geographical extent of the project boundary can be clearly established in terms of (a) location of existing and new buildings connected to the district heating system; (b) identification of boilers, sub-stations and connected isolated heating networks; as well as (c) location and interconnections of cogeneration heat extraction units at the power plant; The power plant, from which heat is extracted for feeding the project primary district heating system;
- (2) The power plant from which heat is extracted for the heating network supplies heat to the district heating network, must be in operation for at least 3 years prior to the project activity and operate in accordance with the following conditions:
 - The heat is extracted from supplied by a grid-connected fossil fuel fired power plant;
 - Only one type of fuel is used (a maximum of 1% of auxiliary fuel may be used for start-up, etc.). The same type of fossil fuel is fired in the power plant in the baseline and project scenarios;
 - The project activity does not lead to the increase in the technical lifetime of the power plant and does not result in any major integrated production changes at the power plant;
 - There should be no diversion of heat or steam, which was extracted prior to the start of the project activity for other purposes such as industrial production,³ to the district heating network.

¹ New buildings can only be included as part of the project activity if it can be demonstrated that more than 50% of the heat is supplied from the project power plant rather than from heat-only boilers (see applicability conditions).

² For project activities dealing exclusively with boilers either by means of complete replacement or retrofit or fuel switch in the existing isolated secondary heat distribution at the site of existing boilers, project proponents may resort to the approved methodology AM0056. <<http://cdm.unfccc.int/goto/MPappmeth>>.

³ In such cases, project participants should provide documented evidence of the power plant supply capacity and the confirmation of the financial conditions for the energy supply to industries being independent of the project activity.



(3) All fossil fuel fired heat-only boiler(s) must operate according to the following conditions:

- The heat supplied to the district heating system is only used for heating of buildings and/or hot tap water supply in the residential and/or commercial sector, but not for industrial production processes;
- Only one type of fuel is used in each of the boilers included in the project boundary. (A maximum of 1% of auxiliary fuel may be used for start-up, etc.).

The methodology does not account for the following potential emission reductions, however project activities that include any of these components are still eligible to use the methodology:

- Emission reductions resulting from the supply of hot tap water through the district heating system;
- Emission reductions resulting from the inclusion in the district heating system those areas, where in the baseline scenario heating was provided on an individual basis, e.g. by coal-fired stoves, electric appliances or boilers in individual apartments;
- Emission reductions resulting from heat supply to new residential areas, in cases where more than 50% of the annual heat production originates from heat-only boilers and less than 50% of heat comes from the power plant within the primary district heating system;
- Emission reductions resulting from a decrease in heat losses due to the water losses or from demand-side measures (e.g. insulation of buildings, use of thermostatic valves, behavioral changes due to billing practices).

In addition, the applicability conditions included in the tools referred to above apply.

II. BASELINE METHODOLOGY

Project boundary

The physical delineation of the project boundary includes:

- The site of the power plant, including the cogeneration heat extraction unit(s) and all interrelated production units to account for emissions resulting from changes in power generation and consumption due to the project activity;
- The heat-only boilers that supply heat to the district heating system (e.g. such as peak load boilers);
- The district heating system, including pipes, sub-stations and buildings that are or will be connected to the district heating system.

All heat supplied to final consumers should be measured at each sub-station i as part of the monitoring plan. For this purpose, each isolated district-heating network that is supplied from a sub-station should have a unique identifier. The quantity of heat supplied to each isolated district-heating network should be measured continuously. Figure 1 below illustrates how the project boundary is defined and where the points to measure heat supplied to buildings ($Q_{j,i}$) should be located as well as heat supply to the primary network by the CHP existing power plant and heat only boilers.

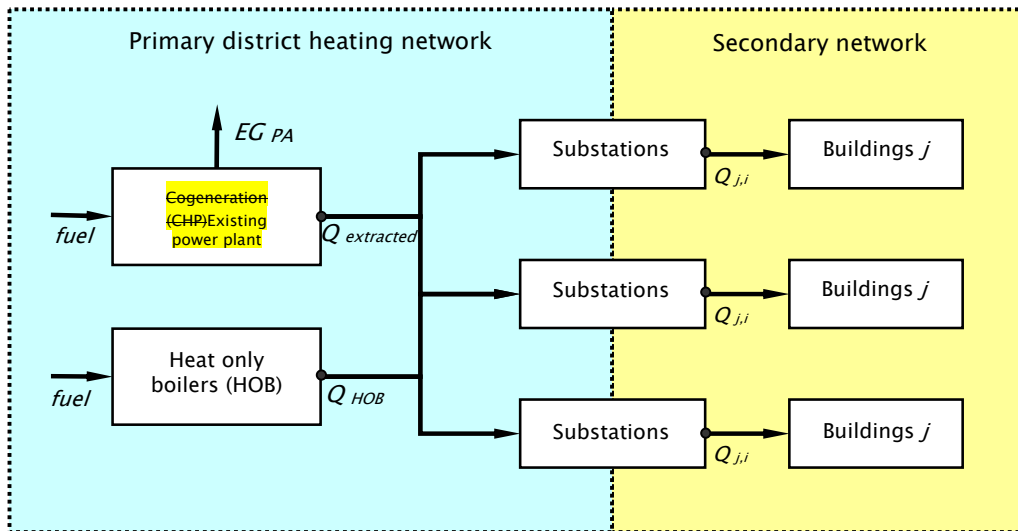

Figure 1

Table 1: Emissions sources included in or excluded from the project boundary

	Source	Gas	Included?	Justification / Explanation
Baseline	Fossil fuel consumption for electricity production	CO ₂	Included	Major emission source.
		CH ₄	Excluded	Excluded for simplification. This is conservative.
		N ₂ O	Excluded	Excluded for simplification. This is conservative.
	Fossil fuel consumption in boiler houses for heat supply	CO ₂	Included	Major emission source.
		CH ₄	Excluded	Excluded for simplification. This is conservative.
		N ₂ O	Excluded	Excluded for simplification. This is conservative.
Project Activity	Fossil fuel consumption for generation of heat and electricity	CO ₂	Included	Major emission source.
		CH ₄	Excluded	Minor emission source. Excluded for simplification.
		N ₂ O	Excluded	Minor emission source. Excluded for simplification.
	Fossil fuel consumption in heat-only boilers that supply heat to the district heating system	CO ₂	Included	Major emission source.
		CH ₄	Excluded	Minor emission source. Excluded for simplification.
		N ₂ O	Excluded	Minor emission source. Excluded for simplification.



Identification of the baseline scenario and demonstration of additionality

Project proponents shall determine the most plausible baseline scenario through the application of the steps prescribed by the latest approved version of the “Combined tool to identify the baseline scenario and demonstrate additionality”.

First of all, categories j for buildings included in the project boundary should be defined on the basis of the following common attributes:

- Type of technology employed by the heating system(s), to which buildings in category j would be connected in the baseline scenario;
- Fuel type used by the heating system(s), to which buildings in category j would be connected in the baseline scenario;
- Type of buildings/sub-area (i.e. existing or new).

Building type/sub-area is the primary categorization and within this category further sub-categorizations relate to technology employed and fuel type used in the baseline heating system(s).

All identified categories j should be described transparently in the CDM-PDD and the choice of categories should be justified by referring to relevant documentary evidence. This should be done on the basis of information obtained from both the responsible heat/urban planning authority and the schematic plan diagrams of the district heating system obtained at the district heating company. All buildings should be included in a filing system, and consistency of information from both sources should be crossed-check. The CDM-PDD should transparently document which buildings belong to which category j . Division of buildings to categories j should be done as an outcome of the baseline identification procedure. Project participants should determine the most plausible baseline scenarios separately for all buildings/sub-areas with similar characteristics as depicted above.⁴

Step 1: Identification of alternative scenarios

Step 1a: Define alternative scenarios to the proposed CDM project activity

Identify all alternative scenarios that are available to the project participants and that provide outputs or services (i.e. heat supply) with comparable quality as the proposed CDM project activity. For the purpose of identifying relevant alternative scenarios, provide an overview of other technologies or practices used for generation of heat that have been implemented prior to the start of the project activity or are currently underway in the relevant geographical area.

⁴ Once an accurate and clear classification of categories j has been done on the basis of the baseline attributes, these categories j shall be assigned to specific points of heat measurement i corresponding to sub-stations introduced as result of the project activity.



The following baseline scenario alternatives for heat supply to buildings or sub-areas with similar characteristics should be assessed:

- (1) Introduction of a new integrated district heating system(s) connected by a new primary network:
 - (a) The proposed project activity undertaken without being registered as a CDM project activity;
 - (b) The introduction of a new district heating system, but with a different configuration for heat generation;
 - (c) The replacement of the heat-only boilers in the existing network(s) by new heat-only boilers.
- (2) Continued operation or rehabilitation of an existing [isolated] district heating network(s) (both existing and new buildings can be connected to an existing network) or establishment of a new [isolated] district heating network(s) (for new buildings) covering all buildings within the project boundary without the introduction of a primary heating network. Such [isolated] district heating network(s) employ the following technologies:
 - (a) Coal fired boilers in boiler houses, supplying several buildings through a small heat distribution network;
 - (b) Natural gas fired boilers in boiler houses, supplying several buildings through a small heat distribution network;
 - (c) Oil fired boilers in boiler houses, supplying several buildings through a small heat distribution network;
 - (d) Small decentralized cogeneration plants;
 - (e) Renewable energy sources, such as biomass or solar thermal collectors, connected to a small heat distribution network.
- (3) Continued use or introduction of building isolated heating networks using:⁵
 - (a) Coal fired boilers for individual buildings;
 - (b) Natural gas fired boilers for individual buildings;
 - (c) Oil fired boilers for individual buildings.
- (4) Continued use or introduction of individual heat supply solutions:⁶
 - (a) Coal fired stoves for individual apartments;
 - (b) Natural gas fired stoves for individual apartments;
 - (c) Oil fired stoves for individual apartments;
 - (d) Electricity (e.g. off-peak storage heating);
 - (e) Individual heating devices using renewable energy sources, e.g. solar thermal collectors;
 - (f) Individual heating devices using non-renewable biomass.

Outcome of Step 1a: List of identified realistic and credible alternative scenarios for all buildings or sub-areas.

⁵ All buildings or sub-areas, where the most likely baseline scenario is found within this category, should have historical information on fuel consumption and thermal output of the isolated heating networks.

⁶ All buildings or sub-areas, where the most likely baseline scenario is found within this category, should be excluded from the project activity.

***Step 1b: Consistency with applicable laws and regulations***

The alternatives shall be in compliance with all mandatory applicable legal and regulatory requirements, even if these laws and regulations have objectives other than GHG reductions, e.g. to mitigate local air pollution. (This sub-step does not consider national and local policies that do not have legally-binding status). If an alternative does not comply with all mandatory applicable legislation and regulations, then show that, based on an examination of current practice in the country or region in which the mandatory law or regulation applies, those applicable mandatory legal or regulatory requirements are systematically not enforced and that non-compliance with those requirements is widespread in the country. If this cannot be shown, then eliminate the alternative from further consideration.

Outcome of Step 1b: List of alternative scenarios to the project activity that are in compliance with mandatory legislation and regulations taking into account the enforcement in the region or country and EB decisions on national and/or sectoral policies and regulations.

Step 2: Eliminate alternatives that face prohibitive barriers

Scenarios that face prohibitive barriers should be eliminated by applying “Step 2 - Barrier analysis” of the latest approved version of the “Combined tool to identify the baseline scenario and demonstrate additionality”.

- If there is only one alternative scenario that is not prevented by any barrier, and if this alternative is not the proposed project activity undertaken without being registered as a CDM project activity, then this alternative scenario is identified as the baseline scenario;
- If there are still several alternative scenarios remaining project participants may choose to either:

Option 1: Go to Step 3 (investment analysis);⁷ or

Option 2: Identify the alternative with the lowest emissions (i.e. the most conservative) as the baseline scenario.

Step 3: Comparison of economic attractiveness of the remaining alternatives

Compare the economic attractiveness without revenues from CERs for alternatives that are remaining by applying “Step 3 - Investment analysis” of the latest approved version of the “Combined tool to identify the baseline scenario and demonstrate additionality”.

- The economic investment analysis shall be based on levelized cost of provided heat (USD/GJ), and explicitly state the following parameters;
- Investment requirements (including break-up into major equipment costs, required construction work, and installation);
- A discount rate appropriate to the country and sector (use government bond rates, increased by a suitable risk premium to reflect private investment in district heating projects, as substantiated by an independent (financial) expert);
- Efficiency of equipment, taking into account any differences between fuels;

⁷ If the investment analysis is carried out, then an investment comparison analysis of the alternatives should be chosen, using the levelized cost of provided heat (in USD/GJ) for each of the alternatives as the financial indicator.



- Current price and expected future price (variable costs) of each fuel. Estimates of the future prices have to be substantiated by a public and official publication from a governmental body or an intergovernmental institution. If such publications are not available, highlight the key logical assumptions and quantitative factors for determining the development of costs of each fuel (e.g. international market price, transport costs, level of taxes/subsidies, local price). State clearly which assumptions and factors have significant uncertainty associated with them, and include these uncertainties in the sensitivity analysis in “Step 3 – investment analysis”;
- Revenues from exporting electricity to the grid, based on the feed-in tariff;
- Operating costs for each fuel (especially, handling/treatment costs for coal);
- Lifetime of the project, equal to the remaining lifetime of the existing facility;
- Other operation and maintenance costs, e.g. of slag and ash disposal, environmental pollution fees etc.

The calculation should be done taking into account the residual value of the new equipment at the end of the lifetime of the project activity. Provide all the assumptions in the CDM-PDD.

Outcome of Step 3: Ranking of the short list of alternative scenarios according to the levelized cost of provided heat taking into account the results of the sensitivity analysis.

- If the sensitivity analysis is not conclusive, identify the alternative with the lowest emissions (i.e. the most conservative);
- If the sensitivity analysis is conclusive and confirms the result of the investment comparison analysis, then the alternative scenario with lowest levelized cost of provided heat is considered as the baseline scenario.

This methodology is only applicable if the identified most plausible baseline scenarios are as follows:

- For existing buildings: continued operation or rehabilitation of an existing isolated district heating network(s) using fossil fuel fired boilers without the introduction of a primary heating network;
- For new buildings: establishment of a new isolated district heating network(s) using fossil fuel fired boilers without the introduction of a primary network.

Additionality

The following steps may be used to assess the additionality or project participants may use the latest “Tool for the demonstration and assessment of additionality” approved by the CDM Executive Board.

Step 1: Analysis of outcome of identification of baseline scenario procedure

- (1) If the proposed project activity is the only alternative amongst the ones considered by the project participants that is in compliance with all mandatory regulations, as identified by applying Step 1a of baseline scenario identification procedure described in section above, with which there is general compliance, then the proposed CDM project activity is not additional.



- (2) If a Barrier analysis is used to identify the baseline scenario, as described in previous section, then:
- If there is only one alternative scenario that is not prevented by any barrier, and if this alternative is the proposed project activity undertaken without being registered as a CDM project activity, then the project activity is not additional;
 - If the proposed project activity undertaken without being registered as a CDM project activity is prevented by any barrier, then explain – using qualitative or quantitative arguments – how the registration of the CDM project activity will alleviate the barriers that prevent the proposed project activity from occurring in the absence of the CDM. If the CDM alleviates the identified barriers that prevent the proposed project activity from occurring, proceed to common practice analysis step, otherwise the project activity is not additional.
- (3) If an Investment analysis⁸ step is used to identify the baseline scenario, and if the proposed project activity undertaken without being registered as a CDM project activity is not prevented by any barrier, then:
- If the sensitivity analysis confirms the result of the investment comparison analysis, and it cannot be ruled out that the lowest levelized cost of provided heat is for “proposed project activity undertaken without being registered as a CDM project activity”, then the project activity is not additional;
 - Else, proceed to common practice analysis step.

Step 2: Common practice analysis

Demonstrate that the project activity is not common practice in the relevant country by applying “Step 4 - Common practice analysis” of the latest version of the “Tool for demonstration assessment and of additionality” agreed by the CDM Executive Board.

Baseline emissions

The baseline emissions include emissions from fossil fuels fired for the production of heat and emissions from the generation of electricity:

$$BE_y = BE_{HG,y} + BE_{EL,y} \quad (1)$$

Where:

BE_y	=	Baseline emissions during the year y , (tCO ₂ e)
$BE_{HG,y}$	=	Baseline emissions from the generation of heat during the year y , (tCO ₂ e)
$BE_{EL,y}$	=	Baseline emissions from the generation of electricity during the year y , (tCO ₂ e)

For the estimation of baseline emissions from the generation of heat the following stepwise approach should be applied:

⁸ If the investment analysis is carried out, then an investment comparison analysis of the alternatives should be chosen, using the levelized cost of provided heat (in USD/GJ) for each of the alternatives as the financial indicator.

**Step 1: Baseline emissions from heat generation**

Baseline emissions from heat generation are estimated as follows:

$$BE_{HG,y} = \sum_i \sum_j Q_{j,i,y} \cdot EF_{BL,HG,j,i} \quad (2)$$

Where:

- $BE_{HG,y}$ = Baseline emissions from the generation of heat during the year y , (tCO₂e)
 $Q_{j,i,y}$ = Estimated quantity of heat supplied from sub-station i to buildings in category j in the year y , (GJ)
 $EF_{BL,HG,j,i}$ = CO₂ emission factor for heat generation for category j connected to sub-station i in the absence of the project activity (tCO₂/GJ)
 j = All categories included in the project boundary defined as combination of building type/technology of boiler/fuel used in boiler
 i = All sub-stations included in the project boundary

The value of heat supplied in the project year y to category j building supplied by substation i is estimated as follows:

$$Q_{j,i,y} = \frac{A_{j,i}}{\sum_j A_{j,i}} * Q_{i,y} \quad (3)$$

Where:

- $A_{j,i}$ = Is total carpet area of buildings in category j connected to substation i
 $Q_{i,y}$ = Is the measured quantity of heat supplied by substation i in year y

- (a) For the cases where the category j consists of existing buildings, as per the definition provided earlier in the procedure for the identification of the baseline scenario, the quantity of heat supplied to this category from sub-station i should be estimated as follows:

$$Q_{j,i,y} = \min \{ Q_{inst_cap,j,i}, Q_{j,i,y} \} \quad (4)$$

Where:

- $Q_{inst_cap,j,i}$ = Maximum quantity of heat that could have been supplied per year by existing boiler(s) supplying to category j building within the area supplied by sub-station i in the absence of the project activity, (GJ), where ' j ' belongs to set of all categories of 'existing buildings' within the sub-station i

In order to determine the maximum quantity of heat $Q_{inst_cap,j,i}$, project proponents should multiply a nameplate capacity value of the boiler supplying to building type j at sub-station i by the number of operational hours per year :

$$Q_{inst_cap,j,i} = CAP_{j,i} \cdot T \quad (4.a)$$



Where:

- $CAP_{j,i}$ = Nameplate capacity of existing boiler(s) using fuel j at sub-station i , (GJ/year)
 T = Number of operational hours per year, recommended default value is 2000 hrs/year⁹

(b) For the cases where category j consists of new buildings, as per the definition provided earlier in the procedure for the identification of the baseline scenario, the quantity of heat supplied to this category should be estimated as follows:

If $Q_{extracted,y} < Q_{HOB,y}$, then $Q_{j,i,y} = 0$;¹⁰

If $Q_{extracted,y} > Q_{HOB,y}$, then $Q_{j,i,y}$ is estimated as per equation 3 above:

Where:

- $Q_{extracted,y}$ = Quantity of heat extracted from the cogeneration plant during the year y , (GJ)
 $Q_{HOB,y}$ = Total quantity of heat extracted from all heat-only boilers supplying to the area covered by primary network during the year y , (GJ)

Step 2: CO₂ emission factor for heat supply in the baseline

CO₂ emission factor for the heat generation in the baseline ($EF_{BL,HG,j,i}$) shall be identified for each category j supplied by sub-station i .

The following factors may influence the CO₂ emission factor:

- The efficiency of the identified baseline technology ($\varepsilon_{HG,BL,j,i}$);
- The fuel type identified as baseline fuel type and respectively the CO₂ emission factor of this fuel ($COEF_{BL,HG,j,i}$);

$EF_{BL,HG,j,i}$ is determined as follows:

$$EF_{BL,HG,j,i} = \frac{COEF_{BL,HG,j,i}}{\varepsilon_{BL,HG,j,i}} \quad (5)$$

Where:

- $EF_{BL,HG,j,i}$ = CO₂ emission factor for the heat generation system corresponding to substation i for category j in the absence of the project activity, (tCO₂/GJ)
 $COEF_{BL,HG,j,i}$ = CO₂ emission factor of the fossil fuel used in the absence of the project activity in the heat generation system corresponding to substation i (tCO₂/GJ)
 $\varepsilon_{BL,HG,j,i}$ = Energy efficiency of the heat supply system i that would be used in the absence of the project activity for buildings in category j

⁹ If a different value is suggested, project proponents shall provide evidence of the operational hours, taking into account seasonal changes.

¹⁰ New buildings can only be included in the project activity, if it can be demonstrated that more than 50% of the heat is supplied by the project power plant rather than from heat only boilers (i.e. see applicability conditions).

**Sub-step 2b: Emission factor of fuel(s) used**

For all categories j , where the identified baseline scenario is the generation of heat in the existing boiler houses or the establishment of new isolated heat distribution networks using fossil fuel fired boilers, project participants should determine $COEF_{BL,HG,j,i}$ corresponding to the fuel type identified in the selection of the baseline scenario.

For all categories j , where the identified baseline scenario is different from the generation of heat in the existing boiler houses or the establishment of new isolated heat distribution networks using fossil fuel fired boilers, project participants should assume $COEF_{BL,HG,j,i} = 0 \text{ tCO}_2/\text{GJ}$.¹¹

For all categories j of new buildings that are attached to a network that is predominantly (more than 50%) supplied by heat from heat-only boilers (rather than from the power plant) project participants should assume $COEF_{BL,HG,j} = 0 \text{ tCO}_2/\text{GJ}$.

Sub-step 2c: Efficiency of boilers used in the absence of the project activity

The efficiency of the boilers that would have been used in the absence of the project activity in boiler houses ($\varepsilon_{BL,HG,j,i}$) should be determined for each category j and each sub-station i and be documented in the CDM-PDD. Once determined, $\varepsilon_{BL,HG,j,i}$ remains fixed for the duration of the crediting period.

To determine $\varepsilon_{BL,HG,j,i}$ project participants may use the following approaches:

- Conduct a representative number of sample measurements of $\varepsilon_{BL,HG,j,i}$ for similar boiler types (e.g. for new coal-fired boilers) at the project site prior to the implementation of the project activity or at other sites with comparable circumstances using the approach described in the latest approved version of AM0044 “Energy efficiency improvement projects: boiler rehabilitation or replacement in industrial and district heating sectors”;
- Use documented manufacturer’s data on the boiler efficiency;
- Use the default values from Table 2 below;¹²
- Determine $\varepsilon_{BL,HG,j,i}$ based on historical fuel consumption data.

Table 2: Default baseline efficiency for different heat supply technologies

Heat supply technology	Default efficiency
State-of-the-art boiler	100%
New natural gas fired boiler (w/o condenser)	92%
New oil fired boiler	90%
Old natural gas fired boiler (w/o condenser)	87%
New coal fired boiler	85%
Old oil fired boiler	85%
Old coal fired boiler	80%

¹¹ This methodology only accounts for emission reductions, if in the absence of the project activity heat would have been generated by boilers installed in boiler houses.

¹² References are contained in Appendix I.



For the purposes of this methodology, “old” boilers are boilers with an individual age of at least 15 years.

Newer boilers are to be considered as “new” or “state-of-the-art”.

Project participants should justify their choice of the baseline efficiency in the CDM-PDD for each of categories j supplied by sub-stations i and demonstrate that conservative values are chosen. For ‘ j =existing’ the project participants can use efficiency value for old boilers provided it is demonstrated that the remaining life time of the boiler, as per procedure described in section below, is more than the crediting period. In the cases of existing buildings this will correspond to the boiler that uses the cleanest fuel in the boiler house and that has been in operation at least once during the three-year period prior to the start of the implementation of the project activity. For this purpose, project participants should provide information about the size, typical age, conditions as well as remaining lifetime of the baseline heat supply systems. For new buildings, either new or state of art boiler efficiency shall be used.

Step 3: Lifetime of existing heat only boiler(s)

In case, where the identified baseline scenario is the continued use of the existing boiler(s), project participants shall, consistent with the guidance by EB 8 and EB 22, determine whether the existing equipment would be replaced, retrofitted or modified during the project lifetime. In order to determine the point in time by when the existing boiler(s) would be replaced in the absence of the project activity, project participants should estimate the typical technical lifetime of the boilers for each of categories j , taking into account the following:

- (a) The typical average technical lifetime of equipment should be determined taking into account common practices in the sector and country (e.g. based on industry surveys, statistics, technical literature, etc.);or
- (b) The practices of the responsible company regarding replacement schedules may be evaluated and documented (e.g. based on historical replacement records for similar equipment).

The estimated typical technical lifetime of boilers for each identified category j should be documented and justified in the CDM-PDD. Prior to the implementation of the project activity, project participants should determine the age of each boiler within each category j that is replaced by the project district heating system, and the average age of the boilers per category j should be calculated weighted by their annual heat generation (in GJ). From this, the average remaining lifetime of the boilers for each category j is calculated as the difference between the typical technical lifetime in j and the average age of boilers in category j .

The length of the crediting period of the project activity may not exceed the calculated average remaining lifetime of boilers in the category j with the shortest average remaining lifetime of boilers.

Baseline emissions from the power generation

The *ex post* calculation of baseline emissions from the power generation is based on the actual monitored electricity generated and supplied to the grid in the project activity and limited by the maximum historic annual amount of electricity generated over the three most recent years prior to the start of implementation of project activity:



$$BE_{EL,y} = \min \{EG_{\max,hist}; EG_{PA,y}\} \cdot EF_{BL,EL} \quad (6)$$

Where:

- $BE_{EL,y}$ = Baseline emissions from the generation of electricity during the year y , (tCO₂e)
 $EF_{BL,EL}$ = Baseline emission factor for the electricity production, (tCO₂/MWh)
 $EG_{PA,y}$ = Monitored actual quantity of electricity supplied to the grid in the year y , (MWh)
 $EG_{\max,hist}$ = Maximum historic annual amount of electricity supplied to the grid over the three most recent years prior to the start of the project activity, (MWh)

$$EF_{BL,EL} = \frac{44}{12} \cdot \frac{3.6}{1000} \cdot \frac{EF_{FF,BL,EL}}{NCV_{FF,BL,EL} \cdot \eta_{BL,EL}} \quad (7)$$

Where:

- $EF_{FF,BL,EL}$ = CO₂ emission factor for the fossil fuel fired in the power plant used prior to the start of the implementation of the project activity, (tC/mass or volume unit)
 $NCV_{FF,BL,EL}$ = Net calorific value of fossil fuel fired in the power plant used prior to the start of the implementation of the project activity (TJ/mass or volume unit)
 $\eta_{BL,EL}$ = Efficiency of the power plant used prior to the start of the implementation of the project activity

Energy efficiency of the power plant (without heat extraction) prior to the start of the project activity ($\eta_{BL,EL}$) can be either measured according to the manufacturers' procedures to measure efficiency at the commissioning or the plant; or taken from the manufacturer's specification of efficiency at optimum load.

The values determined for $\eta_{BL,EL}$ should be documented in the CDM-PDD and shall in general remain fixed throughout the crediting period. However, if during the crediting period a technical measure is taken to improve efficiency of the project power plant and the efficiency increases by x percentage point, then the efficiency of the baseline power plant $\eta_{BL,EL}$ should also be increased by the same x percentage point.

Project emissions

Project emissions PE_y comprise:

- CO₂ emissions from fossil fuel combustion associated with the production of heat and electricity in the CHP power plant;
- CO₂ emissions from fossil fuel combustion in heat-only boilers.

These emissions are calculated using the latest approved version of the "Tool to calculate project or leakage CO₂ emissions from fossil fuel combustion", where the process j corresponds to (a) combustion of fossil fuel at the co-generation plant and (b) combustion of fossil fuel at the heat-only boilers respectively.

PE_y will be estimated as $\sum_j PE_{FC,i,y}$ where $PE_{FC,j,y}$ is calculated as per the Tool.

**Leakage**

Leakage emissions are calculated as follows:

$$LE_y = LE_{EL,y} + LE_{FS,y} \quad (8)$$

Where:

LE_y	=	Leakage emissions in the year y , (tCO ₂ e)
$LE_{EL,y}$	=	Leakage emissions from the decrease in the electricity supply to the grid during the year y , (tCO ₂ e)
$LE_{FS,y}$	=	Leakage emissions from fuel switch during the year y , (tCO ₂ e)

Leakage due to decrease in electricity supply to the grid from the power plant

The decrease in the electricity supply to the grid, as a consequence of the project activity may result in an increase in the electricity supply from other power plants connected to the grid and their related emissions. In this case, leakage emissions are to be accounted for as per the procedure below:

If

$$EG_{PA,y} < EG_{min,hist}$$

And

$$EF_{grid} > EF_{BL,EL}$$

Then

$$LE_{EL,y} = (EG_{min,hist} - EG_{PA,y}) \times (EF_{grid} - EF_{BL,EL}) \quad (9)$$

Where:

$LE_{EL,y}$	=	Leakage emissions from the decrease in the electricity supply to the grid during the year y , (tCO ₂ e)
$EG_{min,hist}$	=	Minimum historic annual amount of electricity supplied to the grid over the three most recent years prior to the start of the project activity, (MWh)
$EG_{PA,y}$	=	Monitored actual quantity of electricity supplied by the project activity to the grid in the year y , (MWh)
EF_{grid}	=	Emission factor of the electricity grid system (tCO ₂ /MWh)
$EF_{BL,EL}$	=	Baseline emission factor for the electricity production, as calculated in the baseline emissions section (tCO ₂ /MWh)

In all other cases $LE_{EL,y} = 0$.



The EF_{grid} is to be calculated using the latest version of the “Tool to calculate the emission factor for an electricity system”, available in the UNFCCC website.

Leakage due to fuel switch

No calculation of leakage effect is required for project activities using the same fossil fuel type in the project activity and in the baseline scenario.

In cases, where the project activity results in a fuel switch from predominantly coal or oil to predominantly natural gas (e.g. from coal fired in the existing boilers to natural gas in the power plant), upstream emissions associated with the production, processing, transportation and distribution of fossil fuels may be significant and are considered as part of leakage emissions $LE_{FS,y}$ to be estimated applying the approach of the latest approved version of AM0029.

Emission Reductions

Emission reductions are calculated as follows:

$$ER_y = BE_y - PE_y - LE_y \quad (10)$$

Where:

ER_y	=	Emission reductions due to the project activity during the year y , (tCO ₂ e)
BE_y	=	Baseline emissions during the year y , (tCO ₂ e)
PE_y	=	Project emissions during the year y , (tCO ₂ e)
LE_y	=	Leakage emissions in the year y , (tCO ₂ e)

Changes required for methodology implementation in 2nd and 3rd crediting periods

This methodology is only applicable to one crediting period of up to ten years.

Data and parameters not monitored

The methodology includes certain parameters and variables that are determined at the beginning of the project activities *ex ante* or through the first monitoring report and then remain fixed during the crediting period. However in some cases the option to monitor the same parameters has also been given, where this option is given the parameter is included in the monitoring section.

Data / Parameter:	Average remaining lifetime of boilers for category j
Data unit:	Years
Description:	Average lifetime of boilers
Source of data:	Documented boiler information
Measurement procedures (if any):	Lifetime of existing heat-only boiler(s). Comparing information about "year of construction" of all boilers for all categories j , with typical technical lifetime of the boilers for all categories j (estimated taking into account the practices in the country and region). Evidence to be presented in the CDM-PDD
Any comment:	



Data / Parameter:	$CAP_{j,i}$
Data unit:	GJ/year
Description:	Nameplate capacity of existing boiler(s) in category j at sub-station i
Source of data:	Manufacture's specifications
Measurement procedures (if any):	
Any comment:	

Data / Parameter:	$EG_{max,hist}$
Data unit:	MWh
Description:	Maximum annual amount of electricity supplied by the power plant to the grid prior to the start of the project activity during the last 3 years before project implementation
Source of data:	Historic production data of last 3 years
Measurement procedures (if any):	
Any comment:	

Data / Parameter:	$EG_{min,hist}$
Data unit:	MWh
Description:	Minimum annual amount of electricity supplied by the power plant to the grid prior to the start of the project activity during the last 3 years before project implementation
Source of data:	Historic production data of last 3 years
Measurement procedures (if any):	
Any comment:	



Data / Parameter:	COEF _{BL,HG,j,i}											
Data unit:	ton CO ₂ /GJ fuel											
Description:	CO ₂ emission factor of the baseline fuel(s) of the heat production in the categories of <i>j</i>											
Source of data:	The following data sources may be used if the relevant conditions apply:											
	<table border="1"> <thead> <tr> <th>Data sources</th> <th>Condition for using the data sources</th> </tr> </thead> <tbody> <tr> <td>(a) Values provided by the fuel supplier in invoices;</td> <td>This is the preferred source.</td> </tr> <tr> <td>(b) Measurements by the project participants;</td> <td>If (a) is not available</td> </tr> <tr> <td>(c) Regional or national default values;</td> <td>If (a) is not available These sources can only be used for liquid fuels and should be based on well documented, reliable sources (such as national energy balances).</td> </tr> <tr> <td>(d) IPCC default values at the upper limit of the uncertainty at the 95% confidence interval as provided in table 1.4 of Chapter 1 of vol. 2 (Energy) of 2006 IPCC Guidelines on National GHG Inventories.</td> <td>If (a) is not available</td> </tr> </tbody> </table>	Data sources	Condition for using the data sources	(a) Values provided by the fuel supplier in invoices;	This is the preferred source.	(b) Measurements by the project participants;	If (a) is not available	(c) Regional or national default values;	If (a) is not available These sources can only be used for liquid fuels and should be based on well documented, reliable sources (such as national energy balances).	(d) IPCC default values at the upper limit of the uncertainty at the 95% confidence interval as provided in table 1.4 of Chapter 1 of vol. 2 (Energy) of 2006 IPCC Guidelines on National GHG Inventories.	If (a) is not available	
Data sources	Condition for using the data sources											
(a) Values provided by the fuel supplier in invoices;	This is the preferred source.											
(b) Measurements by the project participants;	If (a) is not available											
(c) Regional or national default values;	If (a) is not available These sources can only be used for liquid fuels and should be based on well documented, reliable sources (such as national energy balances).											
(d) IPCC default values at the upper limit of the uncertainty at the 95% confidence interval as provided in table 1.4 of Chapter 1 of vol. 2 (Energy) of 2006 IPCC Guidelines on National GHG Inventories.	If (a) is not available											
Measurement procedures (if any):	Once during the first year of the project For (a) and (b) measurements should be undertaken in line with national or international fuel standards											
Any comment:	For (a): If the fuel supplier does provide the NCV value and the CO ₂ emission factor on the invoice and these two values are based on measurements for this specific fuel, this CO ₂ factor should be used. If another source for the CO ₂ emission factor is used or no CO ₂ emission factor is provided, options (b), (c) or (d) should be used											



Data / Parameter:	$\epsilon_{BL,HG,j,i}$
Data unit:	%
Description:	Efficiency of the heat supply system that would have been used in the absence of the project activity for category <i>j</i> and sub-station <i>i</i>
Source of data:	Conduct a representative number of sample measurements of $\epsilon_{BL,HG,j,i}$ for categories of similar boiler types (e.g. for new coal-fired boilers) at the project site prior to the implementation of the project activity or at other sites with comparable circumstances
Measurement procedures (if any):	<i>Sample measurement</i> Use recognized standards for the measurement of the boiler efficiency, such as the “British Standard Methods for Assessing the thermal performance of boilers for steam, hot water and high temperature heat transfer fluids” (BS845). Where possible, use preferably the direct method (dividing the net heat generation by the energy content of the fuels fired during a representative time period), as it is better able to reflect average efficiencies during a representative time period compared to the indirect method (determination of fuel supply or heat generation and estimation of the losses). Document measurement procedures and results and manufacturer’s information transparently in the CDM-PDD
Any comment:	Alternatively, project proponents may use manufacturer data or default values as presented in Sub-step 2c: Efficiency of boilers used in the absence of the project activity

Data / Parameter:	$EF_{FF,BL,EL}$										
Data unit:	tC/mass or volume unit										
Description:	CO ₂ emission factor for the fossil fuel fired in the power plant used prior to the start of the implementation of the project activity										
Source of data:	The following data sources may be used if the relevant conditions apply: <table border="1" style="width: 100%; border-collapse: collapse;"> <thead> <tr> <th style="width: 60%;">Data source</th> <th style="width: 40%;">Conditions for using the data source</th> </tr> </thead> <tbody> <tr> <td>(a) Values provided by the fuel supplier in invoices;</td> <td>This is the preferred source.</td> </tr> <tr> <td>(b) Measurements by the project participants;</td> <td>If (a) is not available</td> </tr> <tr> <td>(c) Regional or national default values;</td> <td>If (a) is not available These sources can only be used for liquid fuels and should be based on well-documented, reliable sources (such as national energy balances).</td> </tr> <tr> <td>(d) IPCC default values at the upper limit of the uncertainty at a 95% confidence interval as provided in table 1.4 of Chapter1 of Vol. 2 (Energy) of the 2006 IPCC Guidelines on National GHG Inventories.</td> <td>If (a) is not available</td> </tr> </tbody> </table>	Data source	Conditions for using the data source	(a) Values provided by the fuel supplier in invoices;	This is the preferred source.	(b) Measurements by the project participants;	If (a) is not available	(c) Regional or national default values;	If (a) is not available These sources can only be used for liquid fuels and should be based on well-documented, reliable sources (such as national energy balances).	(d) IPCC default values at the upper limit of the uncertainty at a 95% confidence interval as provided in table 1.4 of Chapter1 of Vol. 2 (Energy) of the 2006 IPCC Guidelines on National GHG Inventories.	If (a) is not available
Data source	Conditions for using the data source										
(a) Values provided by the fuel supplier in invoices;	This is the preferred source.										
(b) Measurements by the project participants;	If (a) is not available										
(c) Regional or national default values;	If (a) is not available These sources can only be used for liquid fuels and should be based on well-documented, reliable sources (such as national energy balances).										
(d) IPCC default values at the upper limit of the uncertainty at a 95% confidence interval as provided in table 1.4 of Chapter1 of Vol. 2 (Energy) of the 2006 IPCC Guidelines on National GHG Inventories.	If (a) is not available										



Measurement procedures (if any):	For (a) and (b): Measurements should be undertaken in line with national or international fuel standards. For (a): If the fuel supplier does provide the NCV value and the CO ₂ emission factor on the invoice and these two values are based on measurements for this specific fuel, this CO ₂ factor should be used. If another source for the CO ₂ emission factor is used or no CO ₂ emission factor is provided, options (b), (c) or (d) should be used.
Any comment:	Fixed as part of first monitoring period

Data / Parameter:	NCV _{FF,BL,EL}
Data unit:	TJ/mass or volume unit
Description:	Net calorific value of fossil fuel fired in the power plant used prior to the start of the implementation of the project activity
Source of data:	Preferably invoices from fuel supplier or use accurate and reliable local or national data where available.
Measurement procedures (if any):	Use mass or volume meters
Any comment:	Where such local or national data are not available, IPCC default emission factors (country-specific, if available) may be used if they are deemed to reasonably represent local circumstances

Data / Parameter:	Subscript <i>j</i>
Data unit:	
Description:	Categories grouped by (i) type of buildings (new/existing), (ii) type of technology used and (iii) fuel type used in the absence of the project activity. For each category <i>j</i> , all connected buildings should be clearly identified.
Source of data:	The responsible heat or urban planning authority and the maps or schematic-plan diagrams of the district heating system obtained at the district heating company
Measurement procedures (if any):	N/A
Any comment:	Data shall be stored in a database/excel sheet and checked during first monitoring report

Data / Parameter:	Subscript <i>i</i>
Data unit:	
Description:	Sub-station
Source of data:	The responsible heat or urban planning authority and the maps or schematic-plan diagrams of the district heating system obtained at the district heating company
Measurement procedures (if any):	
Any comment:	Data shall be stored in a database/excel sheet and checked during first monitoring report



Data / Parameter:	$\eta_{BL,EL}$
Data unit:	%
Description:	Efficiency of the power plant used prior to the start of the implementation of the project activity
Source of data:	
Measurement procedures (if any):	Can be either measured according to the manufacturers' procedures to measure efficiency at the commissioning of the plant; or taken from the manufacturer's specification of efficiency at optimum load.
Any comment:	Shall in general remain fixed throughout the crediting period. However, if during the crediting period a technical measure is taken to improve efficiency of the project power plant and the efficiency increases by x%, then the efficiency of the baseline power plant $\eta_{BL,EL}$ should also be increased by the same x%.

III. MONITORING METHODOLOGY

Monitoring procedures

Monitoring in this methodology includes the monitoring of parameters used for calculation of both baseline emissions and project emissions.

All heat supplied to final consumers should be measured at each sub-station i as part of the monitoring plan. For each isolated district heating network connected to a sub-station i , the quantity of heat supplied should be measured continuously. If points of heat measurement are changed (e.g. due to a change in the heating network) or added during the crediting period (e.g. due to the construction of new buildings within the project boundary), this should be documented transparently in the CDM-PDD and the monitoring reports.

Note that meters should be installed in a manner that ensures that only the quantity of heat supplied for room heating purposes is metered and additional quantities of heat supplied for hot tap water demand within the project boundary.

All monitored data should be recorded in an electronic database (e.g. Excel sheets) with specifications of the points of measurement, the variable name and description, the corresponding value and unit as well as the time of measurement, the period for which the measurement is valid and the persons who are responsible for making the measurements and carrying out the records. An extract of the complete database shall be included in each monitoring report.

Data to be monitored for determination of the baseline emissions:

- The quantity of heat supplied by the district heating system during each year for each point of heat measurement i : For that purpose meters should be installed at all points of heat measurement i . The corresponding heat delivery has to be measured continuously and recorded at least annually. The meter readings should be documented in the above-mentioned database. The meter readings have to be crosschecked against the meter readings of the heat extracted from the power plant as well as against fuel consumption and heat invoices to ensure that the heat records are plausible and



reliable. Moreover, the corresponding meters have to be subject to regular maintenance and calibration in order to ensure measurements with a low degree of uncertainty;

- Amount of electricity generated in project activity.

Data to be monitored for determination of the project emissions:

- For parameters to be monitored for the calculation of project emissions please refer to the latest approved version of the “Tool to calculate project or leakage CO₂ emissions from fossil fuel combustion”.

Data and parameters monitored

Data / Parameter:	Status of the district heating system and capacity
Data unit:	Number of substations and corresponding MWheat
Description:	Dates of commissioning and status of rated capacity of boilers
Source of data:	The responsible heat or urban planning authority and the maps or schematic-plan diagrams of the district heating system obtained at the district heating company
Measurement procedures (if any):	Maps or schematic-plan diagrams of the district heating system should be updated on the basis of information from boiler supplier, manufacturers specification or catalogue references and SCADA systems
Monitoring frequency:	Recorded at start of the project and whenever the newly installed substations start producing thermal energy
QA/QC procedures:	Data gathered monthly to establish starting date for each substation and monthly status of the scope of the district heating system
Any comment:	

Data / Parameter:	$Q_{\text{extracted},y}$
Data unit:	GJ
Description:	Quantity of heat extracted from the cogeneration plant during the year y
Source of data:	Heat meter at supply side of heat exchanger
Measurement procedures (if any):	Hourly measurement of in- and out flow temperatures and water flow in m ³
Monitoring frequency:	Hourly measurements, registered for the project at least on an annual basis
QA/QC procedures:	The meter readings should be crosschecked against the meter readings of the point of heat supply as well as against heat invoices to district heating company to ensure that the heat records are plausible and reliable. Moreover, the corresponding meters have to be subject to regular maintenance in order to ensure measurements with a low degree of uncertainty. Data to be stored electronically (database)
Any comment:	



Data / Parameter:	$Q_{HOB,y}$
Data unit:	GJ
Description:	Quantity of heat extracted from all heat only/peak load boilers during the year y
Source of data:	Heat meter at supply side of any heat only boiler or peak load boiler
Measurement procedures (if any):	Hourly measurement of in- and out flow temperatures and water flow in m^3
Monitoring frequency:	Hourly measurements, registered for the project at least on an annual basis
QA/QC procedures:	The meter readings should be cross-checked against the meter readings of the point of heat supply as well as against heat invoices to district heating company to ensure that the heat records are plausible and reliable. Moreover, the corresponding meters have to be subject to regular maintenance in order to ensure measurements with a low degree of uncertainty. Data to be stored electronically (database)
Any comment:	

Data / Parameter:	$A_{j,i}$
Data unit:	sq. m
Description:	Total carpet area of all the building in category j supplied by substation i
Source of data:	Estimations available from actual measurement or local authorities
Measurement procedures (if any):	Yearly measurement
Monitoring frequency:	
QA/QC procedures:	

Data / Parameter:	$Q_{i,y}$
Data unit:	GJ
Description:	Quantity of heat supplied from sub-station i to category j buildings
Source of data:	On site measurements of heat meter at sub station
Measurement procedures (if any):	Hourly measurement of in- and out flow temperatures and water flow in m^3
Monitoring frequency:	Hourly measurements, registered for the project at least on an annual basis
QA/QC procedures:	The meter readings should be cross-checked against the meter readings of the heat extracted from the power plant as well as against heat invoices to ensure that the heat records are plausible and reliable. Moreover, the corresponding meters have to be subject to regular maintenance in order to ensure measurements with a low degree of uncertainty. Data to be stored electronically (database).
Any comment:	



Data / Parameter:	$EG_{PA,y}$
Data unit:	MWh
Description:	Actual quantity of electricity supplied to the grid in the year y
Source of data:	Electricity meter
Measurement procedures (if any):	
Monitoring frequency:	Continuous
QA/QC procedures:	
Any comment:	

Data / Parameter:	$PE_{FC,i,y}$
Data unit:	tCO _{2e}
Description:	Project emissions from fossil fuel combustion in process j during the year y
Source of data:	Calculated as per the “Tool to calculate project or leakage CO ₂ emissions from fossil fuel combustion”.
Measurement procedures (if any):	As per the “Tool to calculate project or leakage CO ₂ emissions from fossil fuel combustion”
Monitoring frequency:	As per the “Tool to calculate project or leakage CO ₂ emissions from fossil fuel combustion”
QA/QC procedures:	As per the “Tool to calculate project or leakage CO ₂ emissions from fossil fuel combustion”
Any comment:	-

Data / Parameter:	EF_{grid}
Data unit:	tCO ₂ /MWh
Description:	Emission factor of the electricity grid system
Source of data:	Calculated as per the “Tool to calculate the emission factor for an electricity system”.
Measurement procedures (if any):	As per the “Tool to calculate the emission factor for an electricity system”
Monitoring frequency:	As per the “Tool to calculate the emission factor for an electricity system”
QA/QC procedures:	As per the “Tool to calculate the emission factor for an electricity system”
Any comment:	-



Appendix 1

Source of data and reference for the default efficiency values provided in Table 1

Heat supply system	Efficiency	Source
Gas fired boilers	75-92%	Efficiency of gas boilers. Source: Beijing Heating Energy Conservation Project, World Bank 2005 - internal working note
Oil fired boilers	82% (Range: 65-90%)	Average value of sample measurements in 80 existing oil-fired boilers in Peru. Source: Herold / Schneider / Vizcarra (2003): Improving Energy Efficiency in Peruvian Boilers with the CDM. GTZ/Öko-Institut, Berlin, January 2003
Coal fired boiler	85%	Age: new, condition: excellent, remaining lifetime: many years. Poland. Source: Coal to Gas Conversion Project, GEF Project Document, Report No: 13054, 1994/10/31
Coal fired boiler	65%	Age: middle, condition: good, remaining lifetime: several years. Poland. Source: Coal to Gas Conversion Project, GEF Project Document, Report No: 13054, 1994/10/31
Coal fired boiler	50%	Age: old, condition: poor/fair, remaining lifetime: none/few years. Poland. Source: Coal to Gas Conversion Project, GEF Project Document, Report No: 13054, 1994/10/31
Coal-fired boiler	80%	Efficiency of heat-only boiler in good condition. Estimate of Chinese expert. Source: Personal communication from COWI
Coal fired boiler	45-75%	Average efficiency of heat-only boilers (depending on size, year, location as well as operation and management). Estimate of Chinese expert. Source: Personal communication from COWI
Coal-fired boiler	above 80%	Efficiency level for coal-fired industrial boilers in developed countries. Source: China: Efficient industrial boilers, GEF Focal area: Climate Change, http://www.gefweb.org/COUNCIL/council7/wp/china_br.htm
Coal fired boiler	60-65%	Typical efficiency levels for Chinese coal-fired industrial boilers. Source: China: Efficient industrial boilers, GEF Focal area: Climate Change, http://www.gefweb.org/COUNCIL/council7/wp/china_br.htm
Coal fired boiler	65% (70-80%)	Efficiency of a coal fired industrial boiler (under operation) in 2000 (2010). Source: China Medium and Long Term Energy Conservation Plan, November 25, 2004, National Development and Reform Commission, Table 2. Energy Efficiency Indicators of Major Energy Consuming Equipment
Coal fired boiler	50-75%	Efficiency of coal boilers. Source: Beijing Heating Energy Conservation Project, World Bank 2005 - internal working note



History of the document

Version	Date	Nature of revision(s)
03	EB 47, Annex 4 28 May 2009	Revision to: <ul style="list-style-type: none">• Address the issue related to potential leakage emissions when the electricity fed to the grid by the power plant supplying the heat to the project, is significantly lower under the project than under the baseline; and• Include editorial revisions to improve the clarity in the definition of the project activity, i.e. to implement a primary district heating system that uses heat extracted from an existing power plant.
02	EB 42, Annex 5 26 September 2008	The methodology was revised to expand its applicability to backpressure plants.
01	EB 35, Annex 1 19 October 2007	Initial adoption.