



## Approved baseline and monitoring methodology AM0001

### **“~~Incineration-Decomposition~~ of fluoroform (HFC-23) waste streams”**

#### I. SOURCE AND APPLICABILITY

##### Source

This methodology is based on a proposal from the HFC Decomposition Project in Ulsan, Republic of Korea whose Baseline study, Monitoring and Verification Plan and Project Design Document were prepared by INEOS Fluor Japan Limited (Japan), Foosung Tech Corporation Co., Ltd. (Korea) and UPC Corporation Ltd. (Korea) (version 2.4, July 8, 2003).

This methodology also refers to the latest approved versions of the following tools:

- “Tool to calculate project or leakage CO<sub>2</sub> emissions from fossil fuel combustion”;
- “Tool to calculate baseline, project and/or leakage emissions from electricity consumption”;
- “Tool to assess the validity of the original/current baseline and to update the baseline at the renewal of a crediting period”.

For more information regarding the proposed new methodology and the tools as well as their consideration by the Executive Board please refer to <<http://cdm.unfccc.int/goto/MPappmeth>>.

The methodology also incorporates elements from the “Guidance on accounting eligible HFC-23”, contained in Annex 8 of the report of the thirty-ninth meeting of the CDM Executive Board. Therefore, this document is not applicable to this version of the methodology.

##### **Selected approach from paragraph 48 of the CDM modalities and procedures**

“Existing actual or historical emissions, as applicable”.

##### **Definitions**

The following definitions apply to this methodology:

**HCFC-22 production plant.** A chemical plant which produces chlorodifluoromethane (HCFC-22) either as an independent facility or as a part of an integrated complex. An HCFC-22 production plant may consist of one or several HCFC-22 production lines. The HCFC-22 production plant shall include all production lines located at the project activity site.

**HCFC-22 production line.** An HCFC-22 production line includes one or several HCFC-22 reaction units, the subsequent distillation process and storage tank. It is characterized by the feature that HCFC-22 produced in one production line can be identified from HCFC-22 produced in other production lines.



**HCFC-22 reaction unit.** The HCFC-22 reaction unit comprises the reactor, column and condenser where HCFC-22 is produced through chemical reaction and fluoroform (HFC-23) is formed through over-fluorination of HCFC-22.

**Swing plant.** A chemical plant which can produce either (a) HCFC-22 or (b) Chlorofluorocarbon-11 (CFC-11) and/or Chlorofluorocarbon-12 (CFC-12).

**HFC-23 decomposition facility.** A facility, such as an incinerator, which decomposes HFC-23 into CO<sub>2</sub>, hydrogen fluoride (HF) and other gases that are neither greenhouse gases nor ozone depleting substances.

**Project activity site.** The project activity site includes the entire chemical complex where HCFC-22 is produced, including all production lines located at the complex.

**Waste generation rate  $w$ .** The ratio of mass of HFC-23 formed per unit mass of HCFC-22 produced in a HCFC-22 production line or plant.

**Emissive application.** The use of HCFC-22 for the purpose where HCFC-22 is not transformed in a chemical reaction into another compound. This includes, inter alia, the use of as refrigerant or foam blowing agent.

**Non-emissive application.** The use of HCFC-22 for purposes where HCFC-22 is transformed in a chemical reaction into another compound. This includes, inter alia, the production of polytetrafluoroethylene (PTFE).

**Monitoring period  $m$ .** The period for which a monitoring report is submitted, the verification is performed and for which issuance of CERs is requested by the Designated Operational Entity (DOE). A monitoring period can be of shorter duration than one year, but all the monitoring periods within a year  $y$  of the crediting period should add up to the duration of the year. For example, if a year includes four monitoring periods, the starting date of the first monitoring period should be the same as the starting date of the year  $y$  of the crediting period and the end date of the last monitoring period (fourth in this case) should be the end date of the year  $y$  of the crediting period. Under this methodology, emission reductions are calculated for each monitoring period  $m$ .

**Year  $y$  of the crediting period.** A year  $y$  of the crediting period is defined on the basis of the starting date of the crediting period of the project activity. For example, if the starting date of the crediting period is 15 June, then the year  $y$  of the crediting period for the project activity starts on 15 June and ends in the subsequent calendar year on 14 June.

### Applicability

This methodology is applicable to project activities which capture and decompose HFC-23 formed in the production of HCFC-22. The HFC-23 is decomposed in one or several HFC-23 decomposition facilities which are installed at the project activity site. A single HFC-23 decomposition facility may be used for decomposition of HFC-23 from one or several HCFC-22 reaction units. The HCFC-22 produced may be used for emissive and/or non-emissive applications. HFC-23 is formed as a by-product of the HCFC-22 production process, and is either released to atmosphere or (partially) captured and sold to the market or decomposed in a HFC-23 decomposition facility. An example of a production process is illustrated in a figure in Annex 1 to this methodology.



This methodology is applicable under the following conditions:

- At least one HCFC-22 reaction unit at the project activity site has an operating history of at least three years between 1 January 2000 and 31 December 2004 and has been in operation from 2005 until the start of the project activity;
- The HFC-23 decomposition and, if applicable, any temporary storage of HFC-23, occurs only at the project activity site (i.e. no off-site transport occurs);
- No regulation requires the decomposition of the total amount of HFC-23 generated;
- Prior to the implementation of the project activity, no HFC-23 decomposition facility was installed at the project activity site and all HFC-23 generated at the project activity site was released to the atmosphere.
- Historical data on HCFC-22 production, HFC-23 formation and, in the case of swing plants, CFC production and the capacities of HCFC-22 and CFC production are available to project participants for each production line *k*.

In addition, the applicability conditions included in the tools referred to above apply.

## II. BASELINE METHODOLOGY

### Project boundary

All HCFC-22 production lines that are eligible for crediting as per the procedure in step 1 under “Baseline emissions” below shall be included in the project boundary. The emission sources included in, or excluded from the project boundary are shown in Table 1.

**Table 1: Emissions sources included in or excluded from the project boundary**

	Source	Gas	Included?	Justification/Explanation
Baseline Scenario	HFC-23 emissions from HCFC-22 production lines that are eligible for crediting	HFC-23	Yes	Main emission source
Project Activity	Any remaining HFC-23 emissions from HCFC-22 production lines that are eligible for crediting	HFC-23	Yes	May be an important emissions source
	Fossil fuel and electricity consumption for the operation of the HFC-23 decomposition facility(ies)	CO <sub>2</sub>	Yes	Small emission source but included as a conservative approach
		CH <sub>4</sub>	No	Excluded for simplification. This emission source is assumed to be very small
		N <sub>2</sub> O	No	Excluded for simplification. This emission source is assumed to be very small



	Emissions from the decomposition of HFC-23	CO <sub>2</sub>	Yes	Minor emission source but included as a conservative approach and as determination of this source does not require monitoring of additional parameters
--	--	-----------------	-----	--

### Identification of the baseline scenario and demonstration of additionality

In the absence of regulations requiring HFC-23 decomposition, HFC23 is typically released to the atmosphere because a HFC-23 decomposition facility entails capital and operating costs and the operator of the HCFC-22 production plant has no direct economic incentive to incur these costs. The baseline scenario is therefore the continuation of the current practice, i.e. the continued release of HFC-23 up to the amount that is allowed according to applicable regulations in the host country. If the quantity of HFC-23 emitted to the atmosphere under the project activity is lower than the baseline quantity, as calculated below, the project activity is deemed additional.

### Project emissions

Under this methodology, project emissions are calculated for each monitoring period  $m$ . Project emissions include HFC-23 emissions, CO<sub>2</sub> emissions from fossil fuel consumption for the operation of the HFC-23 decomposition facility and CO<sub>2</sub> emissions from the decomposition of HFC-23 to CO<sub>2</sub>. Project emissions in monitoring period  $m$  ( $PE_m$ ) are calculated as follows:

$$PE_m = PE_{HFC23,m} + PE_{CO_2,FF,m} + PE_{CO_2,EL,m} + PE_{CO_2/HFC23,m} \quad (1)$$

Where:

- $PE_m$  = Project emissions in monitoring period  $m$  (t CO<sub>2</sub>e)
- $PE_{HFC23,m}$  = Project emissions of HFC-23 in monitoring period  $m$  (t CO<sub>2</sub>e)
- $PE_{CO_2,FF,m}$  = Project emissions of CO<sub>2</sub> from fossil fuel consumption for the operation of the HFC-23 decomposition facility in monitoring period  $m$  (t CO<sub>2</sub>)
- $PE_{CO_2,EL,m}$  = Project emissions of CO<sub>2</sub> from electricity consumption for the operation of the HFC-23 decomposition facility in monitoring period  $m$  (t CO<sub>2</sub>)
- $PE_{CO_2/HFC23,m}$  = Project emissions of CO<sub>2</sub> from decomposition of HFC-23 in monitoring period  $m$  (t CO<sub>2</sub>)

The four emission sources are determined in the following three steps.

#### Step 1: Determination of $PE_{HFC23,m}$

Project emissions of HFC-23 in monitoring period  $m$  ( $PE_{HFC23,m}$ ) include any HFC-23 emissions from all HCFC-22 production lines that are eligible for crediting as per the procedure in step 1 under “Baseline emissions” below. This includes emissions due to incomplete decomposition of HFC-23 in the HFC-23 decomposition facility, the direct venting of HFC-23 (e.g. through a by-pass to the HFC-23 decomposition facility) and fugitive emissions from storage and other devices connected to the HCFC-22 production lines that are eligible for crediting. Project emissions are not directly measured but are determined based on a HFC-23 mass balance, as the difference between the amount of HFC-23 generated in HCFC-22 production lines that are eligible for crediting ( $\sum Q_{HFC23,gen,k,m}$ ) and the amount of HFC-23 generated as a by-product in these production lines and decomposed in the HFC-23 decomposition facility(ies) ( $Q_{HFC23,dec,m}$ ), as follows:

$$PE_{\text{HFC23},m} = \left( \sum_k Q_{\text{HFC23,gen},k,m} - Q_{\text{HFC23,dec},m} \right) \times GWP_{\text{HFC23}} \quad (2)$$

with

$$Q_{\text{HFC23,dec},m} = \sum_d (Q_{\text{HFC23,dec},d,\text{inlet},m} - Q_{\text{HFC23,dec},d,\text{outlet},m}) \quad (3)$$

Where:

- $PE_{\text{HFC23},m}$  = Project emissions of HFC-23 in monitoring period  $m$  (t CO<sub>2</sub>e)  
 $GWP_{\text{HFC23}}$  = Global Warming Potential of HFC-23 valid for the commitment period (t CO<sub>2</sub>e / t HFC-23)  
 $Q_{\text{HFC23,gen},k,m}$  = Quantity of HFC-23 generated as a by-product in HCFC-22 production line  $k$  in monitoring period  $m$  (t HFC-23)  
 $Q_{\text{HFC23,dec},m}$  = Quantity of HFC-23 that is generated as a by-product in HCFC-22 production lines that are eligible for crediting and that is decomposed in the HFC-23 decomposition facility(ies) in monitoring period  $m$  (t HFC-23)  
 $Q_{\text{HFC23,dec},d,\text{inlet},m}$  = Quantity of HFC-23 that is generated as a by-product in HCFC-22 production lines that are eligible for crediting and that is supplied to the inlet of the HFC-23 decomposition facility  $d$  in monitoring period  $m$  (t HFC-23)  
 $Q_{\text{HFC23,dec},d,\text{outlet},m}$  = Quantity of HFC-23 emitted at the outlet of the HFC-23 decomposition facility  $d$  due to incomplete decomposition of HFC-23 in monitoring period  $m$  (t HFC-23)  
 $k$  = HCFC-22 production lines at the project activity site that are eligible for crediting in monitoring period  $m$   
 $d$  = HFC-23 decomposition facility(ies) operated under the project activity

HFC-23 may be also temporarily stored, e.g. during maintenance of the HFC-23 decomposition facility. However, with the approach applied in equation (2) above, any HFC-23 added to the storage stock in monitoring period  $m$  is accounted as if it would be released to the atmosphere; when it is subsequently destroyed in monitoring period  $m+1$  it is accounted as additional HFC-23 destruction and the project emissions are lowered by this amount. Over the two monitoring periods, the calculated project emissions correspond to the actual amount of HFC-23 released to the atmosphere. Note that this approach for accounting purposes may result in negative project emissions in some monitoring periods.

Project emissions are determined and accounted in this way for two reasons:

- (1) The approach avoids that emission reductions could be claimed from long-term storage of HFC-23 and potential release of the stored HFC-23 after the end of the crediting period;
- (2) The measurement of the quantity of HFC-23 generated and the quantity of HFC-23 decomposed is simpler and easier to verify than measuring all potential project emission sources which may include fugitive emission sources and different by-passes with varying volume flows and concentrations of HFC-23.

An example of the mass balance approach and the accounting of project emissions is provided in Table 2 below. In the example, 30 tons of HFC-23 are stored in the first monitoring period. In the



second monitoring period, the stored amount is decomposed in the HFC-23 decomposition facility. For this reason, the amount of HFC-23 decomposed is larger than the amount of HFC-23 generated at the facility. In the first monitoring period, the amount of HFC-23 stored is accounted as project emission and therefore, the calculated project emissions (50 tons) are 30 tons larger than the actual amount released to the atmosphere. However, the second monitoring period accounts for the fact that the stored HFC-23 was decomposed. For this reason, the calculated project emissions are 30 tons less than the actual amount released to the atmosphere.

**Table 2: Example for a HFC-23 mass balance and accounting of HFC-23 project emissions (metric tons of HFC-23)**

	A	B	C	D=A-B-C	E=A-B
Monitoring report no	HFC-23 generated	HFC-23 decomposed	Addition to HFC-23 storage stock*	HFC-23 released to the atmosphere	Calculated project emissions
1	200	150	30	20	50
2	200	220	-30	10	-20
<b>Total</b>	<b>400</b>	<b>370</b>	<b>0</b>	<b>30</b>	<b>30</b>

\*Positive values mean that the stock of stored HFC-23 was increased by this amount in monitoring period  $m$  and negative values mean that the stock of stored HFC-23 was reduced in monitoring period  $m$  and that the corresponding amount was either decomposed in the HFC-23 decomposition facility or released into the atmosphere.

### Step 2: Determination of $PE_{CO_2,FF,m}$ and $PE_{CO_2,EL,m}$

Project emissions of CO<sub>2</sub> from fossil fuel and electricity consumption for the operation of the HFC-23 decomposition facility(ies) in monitoring period  $m$  ( $PE_{CO_2,FF,m}$  and  $PE_{CO_2,EL,m}$ ) shall be determined using the latest approved version of the “Tool to calculate project or leakage CO<sub>2</sub> emissions from fossil fuel combustion” and “Tool to calculate baseline, project and/or leakage emissions from electricity consumption”. Project emissions from electricity consumption only have to be estimated if the HFC-23 is decomposed by a plasma technology.

The parameter  $PE_{FC,j,y}$  used in the “Tool to calculate project or leakage CO<sub>2</sub> emissions from fossil fuel combustion” corresponds to the parameter  $PE_{CO_2,FF,m}$  in this methodology and the element process  $j$  in the tool corresponds to the consumption of fossil fuels for the operation of the HFC-23 decomposition facility(ies) in monitoring period  $m$ . The parameter  $PE_{EC,y}$  used in the “Tool to calculate baseline, project and/or leakage emissions from electricity consumption” corresponds to the parameter  $PE_{CO_2,EL,m}$  in this methodology and the project electricity consumption source  $j$  corresponds to the consumption of electricity for the operation of the HFC-23 decomposition facility(ies) using plasma technology in monitoring period  $m$ .

### Step 3: Determination of $PE_{CO_2/HFC23,m}$

Project emissions of CO<sub>2</sub> from decomposition of HFC-23 in monitoring period  $m$  ( $PE_{CO_2/HFC23,m}$ ) are determined based on the quantity of HFC-23 decomposed in monitoring period  $m$  ( $Q_{HFC23,dec,m}$ ) and a conversion factor ( $EF_{CO_2/HFC23}$ ) expressing the amount of CO<sub>2</sub> generated per amount of HFC-23 decomposed, as follows:

$$PE_{CO_2/HFC23} = Q_{HFC23,dec,m} \times EF_{CO_2/HFC23} \quad (4)$$



Where:

- $PE_{CO_2/HFC23,m}$  = Project emissions of CO<sub>2</sub> from decomposition of HFC-23 in monitoring period  $m$  (t CO<sub>2</sub>)
- $Q_{HFC23,dec,m}$  = Quantity of HFC-23 decomposed in the HFC-23 decomposition facility(ies) in monitoring period  $m$  (t HFC-23)
- $EF_{CO_2/HFC23}$  = Conversion factor expressing the mass of CO<sub>2</sub> generated per unit mass of HFC-23 decomposed (t CO<sub>2</sub> / t HFC-23)

### Baseline emissions

Baseline emissions include only HFC-23 emissions. Baseline emissions are calculated separately for each HCFC-22 production line  $k$  which is eligible for crediting, as the minimum between:

- The quantity of HFC-23 that is formed in HCFC-22 production line  $k$  and can be emitted to the atmosphere in monitoring period  $m$  according to applicable regulations ( $BE_{HFC23,REG,k,m}$ ); and
- The quantity of HCFC-22 production from production line  $k$  that is eligible for crediting in monitoring period  $m$  ( $Q_{HCFC22,el,k,m}$ ), multiplied by the baseline waste generation rate for production line  $k$  in monitoring period  $m$  ( $w_{BL,HFC23/HCFC22,k,m}$ ).

Accordingly, baseline emissions are calculated as follows:

$$BE_m = \sum_k GWP_{HFC23} \times \text{MIN} \left[ BE_{HFC23,REG,k,m}; Q_{HCFC22,el,k,m} \times w_{BL,HFC23/HCFC22,k,m} \right] \quad (5)$$

Where:

- $BE_m$  = Baseline emissions in monitoring period  $m$  (tCO<sub>2</sub>e)
- $GWP_{HFC23}$  = Global Warming Potential of HFC-23 valid for the commitment period (t CO<sub>2</sub>e / tHFC-23)
- $BE_{HFC23,REG,k,m}$  = Quantity of HFC-23 that is formed in HCFC-22 production line  $k$  and that can be emitted to the atmosphere in monitoring period  $m$  according to applicable regulations (t HFC-23)
- $Q_{HCFC22,el,k,m}$  = Quantity of HCFC-22 that is produced in HCFC-22 production line  $k$  and that is eligible for crediting in monitoring period  $m$  (t HCFC-22)
- $w_{BL,HFC23/HCFC22,k,m}$  = Baseline waste generation rate for HCFC-22 production line  $k$  in monitoring period  $m$  (t HFC-23 / t HCFC-22)
- $k$  = HCFC-22 production lines at the project activity site that are eligible for crediting in monitoring period  $m$

Both parameters, the quantity of HCFC-22 production that is eligible for crediting ( $Q_{HCFC22,el,k,m}$ ) and the baseline waste generation rates ( $w_{BL,HFC23/HCFC22,k,m}$ ), are determined in a conservative manner in order to avoid incentives that:

- More HCFC-22 is produced under the project activity than would be produced in the absence of the project activity; and/or
- The plant is operated under the project activity at a higher HFC-23/HCFC-22 ratio than in the absence of the project activity.

In the following steps, the required parameters are determined. Step 1 determines which HCFC-22 production lines  $k$  are eligible for crediting in monitoring period  $m$ . The quantity of HCFC-22 that is



eligible in monitoring period  $m$  ( $Q_{\text{HCFC22,el,k,m}}$ ) is calculated in step 2. Finally, Step 3 calculates the baseline waste generation rate ( $W_{\text{BL,HFC23/HCFC22,k,m}}$ ).

**Step 1: Determination of HCFC-22 production lines  $k$  that are eligible for crediting in monitoring period  $m$**

A HCFC-22 production line  $k$  is eligible for crediting in monitoring period  $m$  if all the following conditions are met:

- Commercial production of HCFC-22 and/or CFCs in the production line started before 1 January 2002 and has been recorded in each year until the start of the monitoring period  $m$ ;
- The production line has produced HCFC-22 (and not only CFC-11 and/or CFC-12) in at least three calendar years in the period from 2000 to 2004;

All data supporting the determination which HCFC-22 production line  $k$  is eligible should be transparently documented in the CDM-PDD and in the monitoring reports. Project participants may quote data and documents submitted in previous monitoring reports instead of submitting them again.

**Step 2: Determination of  $Q_{\text{HCFC22,el,k,m}}$**

The quantity of HCFC-22 production that is eligible for crediting in monitoring period  $m$  ( $Q_{\text{HCFC22,el,k,m}}$ ) is determined separately for each HCFC-22 production line  $k$  which was identified to be eligible for crediting in monitoring period  $m$ .

In order to avoid incentives to produce more HCFC-22 than would be produced in the absence of the CDM, the amount of HCFC-22 eligible for crediting is capped on an annual basis to the average historical annual HCFC-22 equivalent production level in HCFC-22 production line  $k$  ( $Q_{\text{HCFC22e,k,hist}}$ ).

The annual cap on historical production levels is applied to a monitoring period  $m$  on a pro-rata basis based on the duration of the monitoring period  $m$ .

Accordingly,  $Q_{\text{HCFC22,el,k,m}}$  is determined as follows:

$$Q_{\text{HCFC22,el,k,m}} = \text{MIN} \left[ \begin{array}{l} Q_{\text{HCFC22,k,m}} \\ Q_{\text{HCFC22e,k,hist}} \times \frac{d_m}{d_y} \end{array} \right] \quad (6)$$

Where:

- $Q_{\text{HCFC22,el,k,m}}$  = Quantity of HCFC-22 that is produced in HCFC-22 production line  $k$  and that is eligible for crediting in monitoring period  $m$  (t HCFC-22)
- $Q_{\text{HCFC22,k,m}}$  = Amount of HCFC-22 produced in HCFC-22 production line  $k$  in monitoring period  $m$  (t HCFC-22)
- $Q_{\text{HCFC22e,k,hist}}$  = Average annual HCFC-22 equivalent production level in HCFC-22 production line  $k$  (t HCFC-22)
- $d_m$  = Duration of the monitoring period  $m$  (days)
- $d_y$  = Number of days in the year  $y$  of the crediting period (days)



- k = HCFC-22 production lines at the project activity site that are eligible for crediting in monitoring period *m*
- m = Monitoring period within year *y* of the crediting period for which issuance is requested
- y = Year of the crediting period

The historical HCFC-22 equivalent production level ( $Q_{\text{HCFC22e,k,hist}}$ ) includes the actual HCFC-22 production, plus – in the case of swing plants – an HCFC-22 production equivalent of the CFC production, adjusted appropriately to account for the different production rates of HCFC22 and CFCs.

The historical production period shall include three calendar years *x* within the period from 2000 to 2004. The three last calendar years in which the plant produced HCFC-22 shall be used. If a swing plant produced only CFC-11 and/or CFC-12 in a particular year, this year shall not be included in the three calendar years. For example, if the plant produced HCFC-22 in all years from 2000 to 2004, the years 2002, 2003 and 2004 should be used. If the plant produced HCFC-22 in all years except for 2003, then the years 2001, 2002 and 2004 should be used.

The production of CFC-11 and CFC-12 is included as an equivalent HCFC-22 production only for those production lines *k* and only for those years *x* in which HCFC-22 was actually produced in the production line, i.e. the production of CFC-11 and CFC-12 should not be included for those years where no HCFC-22 production occurred in that production line. The CFC-11 and CFC-12 production is adjusted to an equivalent HCFC-22 production level based on the production capacities of the plant for HCFC-22 production and CFC-11 and CFC-12 production.

Accordingly,  $Q_{\text{HCFC22e,k,hist}}$  is determined as follows:

$$Q_{\text{HCFC22e,k,hist}} = \frac{1}{3} \times \sum_x \left[ Q_{\text{HCFC22,k,x}} + Q_{\text{CFC,k,x}} \times \frac{C_{\text{HCFC22,k}}}{C_{\text{CFC,k}}} \right] \quad (7)$$

Where:

- $Q_{\text{HCFC22e,k,hist}}$  = Average annual HCFC-22 equivalent production level in HCFC-22 production line *k* in the historical three year period from 2002 to 2004 (t HCFC-22 / yr)
- $Q_{\text{HCFC22,k,x}}$  = Amount of HCFC-22 produced in HCFC-22 production line *k* in year *x* (t HCFC-22 / yr)
- $Q_{\text{CFC,k,x}}$  = Amount of CFC-11 and CFC-12 produced in HCFC-22 production line *k* in year *x* (t CFC-11 and CFC-12 / yr)
- $C_{\text{HCFC22,k}}$  = HCFC-22 production capacity of the production line *k* (t HCFC-22 / h)
- $C_{\text{CFC,k}}$  = CFC production capacity of the production line *k* (t CFC-11 and CFC-12 / h)
- k = HCFC-22 production lines at the project activity site that are eligible for crediting in monitoring period *m*
- x = The three historical calendar years in the period from 2000 to 2004 identified as per the guidance above

The HCFC-22 and CFC production capacities for each production line *k* ( $C_{\text{HCFC-22,k}}$  and  $C_{\text{CFC,k}}$ ) should be determined based on historical data from the period 2000 to 2004, by dividing the quantity of HCFC-22 or CFCs produced during a representative time period by that time period. The production capacities should be determined for all production lines separately. Furthermore, both production capacities (for HCFC-22 and the CFC production) should be determined for time periods where the



production line was operating at the same load. Where such historical data is not available, project participants may undertake respective measurements of the HCFC-22 and CFC production capacity at the production line at full load operation. The ratio of  $C_{\text{HCFC-22},k} / C_{\text{CFC},k}$  should not exceed the ratio of the molecular weight of HCFC-22 (86.47) to the molecular weight of the mixture of CFC-11 (137.38) and CFC-12 (120.91) produced in the production line.

The historical production data of HCFC-22 and, in case of swing plants, of CFC-11 and CFC-12 in each production line  $k$  and the determination of the CFC and HCFC-22 production capacities ( $C_{\text{CFC},k}$  and  $C_{\text{HCFC-22},k}$ ) should be documented transparently in the CDM-PDD.

### Step 3: Determination of $w_{\text{BL,HFC23/HCFC22},k,y}$

The baseline waste generation rate for HCFC-22 production line  $k$  in year  $y$  ( $w_{\text{BL,HFC23/HCFC22},k,y}$ ) is determined, as a conservative approach, as the minimum value between a conservative default value ( $w_{\text{default}}$ ) and the lowest waste generation rate achieved in the production line in the past up to the monitoring period  $m$ .

Accordingly,  $w_{\text{BL,HFC23/HCFC22},k,y}$  is calculated as follows:

$$w_{\text{BL,HFC23/HCFC22},k,y} = \text{MIN} [w_{\text{default}} ; w_{\text{MIN},k,m}] \quad (8)$$

Where:

- $w_{\text{BL,HFC23/HCFC22},k,m}$  = Baseline waste generation rate for HCFC-22 production line  $k$  in monitoring period  $m$  (t HFC-23 / t HCFC-22)
- $w_{\text{default}}$  = Conservative default value for the baseline waste generation rate (t HFC-23 / t HCFC-22)
- $w_{\text{MIN},k,m}$  = Minimum waste generation rate achieved by HCFC-22 production line  $k$  up to monitoring period  $m$  (t HFC-23 / t HCFC-22)
- $k$  = HCFC-22 production lines at the project activity site that are eligible for crediting in monitoring period  $m$

The minimum waste generation rate achieved by HCFC-22 production line  $k$  up to monitoring period  $m$  ( $w_{\text{MIN},k,m}$ ) shall be selected from the period from the first year among the three historical years identified in Step 2 above up to the monitoring period  $m$ . For the time period before the start of the crediting period, the determination of  $w_{\text{MIN},k,m}$  shall be based on the average annual waste generation values. For these historical values, direct measurement of the HFC-23 release is to be used where the data is available, otherwise a mass balance based on the carbon efficiency and the flouring efficiency shall be used.

In applying this mass balance approach, it is assumed that 1% of the HCFC-22 is lost due to physical leakage based on a information by Midgley and Fischer (1993). As a conservative approach, the lower value between the carbon efficiency and the fluorine efficiency shall be used.



Accordingly, the historical waste generation rates are determined as follows if a mass balance approach is used:

$$w_{\text{HFC23/HCFC22},k,x} = \text{MIN} \left[ \begin{array}{l} (0.99 - \text{FE}_{k,x}) \times 0.540 \\ (0.99 - \text{CE}_{k,x}) \times 0.809 \end{array} \right] \quad (9)$$

with

$$\text{FE}_{k,x} = \frac{M_{\text{F,HCFC-22},k,x}}{M_{\text{F,HF},k,x}} \quad (10)$$

and

$$\text{CE}_{k,x} = \frac{M_{\text{C,HCFC-22},k,x}}{M_{\text{C,CHCl3},k,x}} \quad (11)$$

Where:

- $w_{\text{HFC23/HCFC22},k,x}$  = Waste generation rate for HCFC-22 production line  $k$  in historical year  $x$  (t HFC-23 / t HCFC-22)
- $\text{FE}_{k,x}$  = Fluorine efficiency of HCFC-22 production line  $k$  in historical year  $x$  (dimensionless)
- $\text{CE}_{k,x}$  = Carbon efficiency of HCFC-22 production line  $k$  in historical year  $x$  (dimensionless)
- $M_{\text{F,HCFC-22},k,x}$  = Mass of fluorine contained in the HCFC-22 produced in HCFC-22 production line  $k$  in historical year  $x$  (t F)
- $M_{\text{F,HF},k,x}$  = Mass of fluorine contained in the hydrogen fluoride fed into HCFC-22 reactor units of HCFC-22 production line  $k$  in historical year  $x$  (t F)
- $M_{\text{C,HCFC-22},k,x}$  = Mass of carbon contained in the HCFC-22 produced in HCFC-22 production line  $k$  in historical year  $x$  (t C)
- $M_{\text{C,HF},k,x}$  = Mass of carbon contained in the hydrogen fluoride fed into HCFC-22 reactor units of HCFC-22 production line  $k$  in historical year  $x$  (t C)
- $k$  = HCFC-22 production lines at the project activity site that are eligible for crediting in monitoring period  $m$
- $x$  = The three historical calendar years in the period from 2000 to 2004 identified as per the guidance above

From the time period after start of the crediting period, the determination of  $w_{\text{MIN},k,m}$  shall be based on the monthly average waste generation rates up to the start of the monitoring period  $m$ . The measurement procedures, calculations and assumptions used to determine  $w$  should be documented transparently in the CDM-PDD and in monitoring reports.

### Leakage

Leakage emissions are deemed to be negligible and are accounted as zero.

**Emission reductions**

Emission reductions in monitoring period  $m$  ( $ER_m$ ) are calculated as follows:

$$ER_m = BE_m - PE_m \quad (12)$$

Where:

- $ER_m$  = Emission reductions in monitoring period  $m$  (t CO<sub>2</sub>e)  
 $BE_m$  = Baseline emissions in monitoring period  $m$  (t CO<sub>2</sub>e)  
 $PE_m$  = Project emissions in monitoring period  $m$  (t CO<sub>2</sub>e)

**Renewal of crediting period**

Project participants shall apply the “Tool to assess the validity of the original/current baseline and to update the baseline at the renewal of a crediting period”.

In updating the parameter  $w_{\text{default}}$  at the renewal of the crediting, the project participants shall evaluate the data from all registered HFC-23 CDM projects. The lowest average value achieved during a period of at least one month shall be used at the renewal of the crediting if this value is lower than the default value established in this methodology.

**Data and parameters not monitored**

<b>Data / Parameter:</b>	$GWP_{\text{HFC23}}$
Data unit:	t CO <sub>2</sub> e / t HFC-23
Description:	Global Warming Potential of HFC-23 valid for the commitment period
Source of data:	Decisions by COP/MOP
Value to be applied:	11,700 for the first commitment period under the Kyoto Protocol
Any comment:	-

<b>Data / Parameter:</b>	$d_y$
Data unit:	days
Description:	Number of days in the year $y$ of the crediting period
Source of data:	-
Value to be applied:	365 or 366
Any comment:	-

<b>Data / Parameter:</b>	$Q_{\text{HCFC22},k,x}$
Data unit:	t HCFC-22
Description:	Amount of HCFC-22 produced in HCFC-22 production line $k$ in year $x$
Source of data:	Records by project participants
Measurement procedures (if any):	If possible, cross-check production records with sales records as well as with information officially reported under the Montreal Protocol
Any comment:	-



<b>Data / Parameter:</b>	$Q_{CFC,k,x}$
Data unit:	t CFC-11 and CFC-12
Description:	Amount of CFC-11 and CFC-12 produced in HCFC-22 production line $k$ in year $x$
Source of data:	Records by project participants
Measurement procedures (if any):	If possible, cross-check production records with sales records as well as with information officially reported under the Montreal Protocol
Any comment:	Applicable in case of swing plants

<b>Data / Parameter:</b>	$C_{HCFC-22,k}$
Data unit:	t HCFC-22 / h
Description:	HCFC-22 production capacity of production line $k$
Source of data:	This value is either based on historical records between 01 January 2000 and 31 December 2004 or measurements. Both should be at the same load levels as the corresponding data on the CFC production rate
Measurement procedures (if any):	If possible, cross-check production records with sales records as well as with information officially reported under the Montreal Protocol
Any comment:	Applicable in case of swing plants

<b>Data / Parameter:</b>	$C_{CFC,k}$
Data unit:	t CFC-11 and CFC-12 / h
Description:	CFC production capacity of production line $k$
Source of data:	This value is either based on historical records between beginning of 2000 and end of 2004 or measurements. Both should be at the same load levels as the corresponding data on the HCFC-22 production rate
Measurement procedures (if any):	
Any comment:	Applicable in case of swing plants

<b>Data / Parameter:</b>	$M_{F,HCFC-22,k,x}$
Data unit:	t F
Description:	Mass of fluorine contained in the HCFC-22 produced in HCFC-22 production line $k$ in historical year $x$
Source of data:	Records by project participants
Measurement procedures (if any):	
Any comment:	Applicable in the case a mass balance approach is used to determine the HFC-23 waste generation rate for years prior to the implementation of the project activity



<b>Data / Parameter:</b>	$M_{F,HF,k,x}$
Data unit:	t F
Description:	Mass of fluorine contained in the hydrogen fluoride fed into HCFC-22 reactor units of HCFC-22 production line $k$ in historical year $x$
Source of data:	Records by project participants
Measurement procedures (if any):	
Any comment:	Applicable in the case a mass balance approach is used to determine the HFC-23 waste generation rate for years prior to the implementation of the project activity

<b>Data / Parameter:</b>	$M_{C,HCFC-22,k,x}$
Data unit:	t C
Description:	Mass of carbon contained in the HCFC-22 produced in HCFC-22 production line $k$ in historical year $x$
Source of data:	Records by project participants
Measurement procedures (if any):	
Any comment:	Applicable in the case a mass balance approach is used to determine the HFC-23 waste generation rate for years prior to the implementation of the project activity

<b>Data / Parameter:</b>	$M_{C,HF,k,x}$
Data unit:	t C
Description:	Mass of carbon contained in the hydrogen fluoride fed into HCFC-22 reactor units of HCFC-22 production line $k$ in historical year $x$
Source of data:	Records by project participants
Measurement procedures (if any):	
Any comment:	Applicable in the case a mass balance approach is used to determine the HFC-23 waste generation rate for years prior to the implementation of the project activity

<b>Data / Parameter:</b>	$EF_{CO_2/HFC23}$
Data unit:	t CO <sub>2</sub> / t HFC-23
Description:	Conversion factor expressing the amount of CO <sub>2</sub> generated per amount of HFC-23 decomposed
Source of data:	Molecular weight balance of the chemical process of conversion of HFC-23 into CO <sub>2</sub> .
Value to be applied:	0.62857
Any comment:	-



<b>Data / parameter:</b>	$W_{\text{default}}$
Data unit:	t HFC-23 / t HCFC-22
Description:	Conservative default value for the baseline waste generation rate
Source of data:	As a conservative approach, a value of 0.01 is used. The IPCC and TEAP reported that thermal oxidation would be required to reduce HFC-23 formation below a 1% level (IPCC/TEAP 2007, page 410). This value also corresponds approximately to the lowest reported and verified waste generation rates achieved by plants in developing countries.
Value to be applied:	0.01
Any comment:	-

### III. MONITORING METHODOLOGY

#### General monitoring provisions

Describe and specify in the CDM-PDD all monitoring procedures, including the type of measurement instrumentation used, the responsibilities for monitoring and QA/QC procedures that will be applied. Where the methodology provides different options (e.g. use of default values or on-site measurements), specify which option will be used. Meters should be installed, maintained and calibrated according to equipment manufacturer instructions and be in line with national standards or, if these are not available, international standards (e.g. IEC, ISO).

In the case of measurements of the flow of streams containing HFC-23, the flow meters shall be calibrated every six months by an officially accredited entity. The zero check on the flow meters shall be conducted every week. If the zero check indicates that the flow meter is not stable, an immediate calibration of the flow meter shall be undertaken.

The quantities of gaseous effluents (CO, HCl, HF, Cl<sub>2</sub>, dioxin and NO<sub>x</sub>) and liquid effluents (PH, COD, BOD, n-H (normal hexane extracts), SS (suspended solid), phenol, and metals (Cu, Zn, Mn and Cr) are measured every six months to ensure compliance with environmental regulations.

All data collected as part of the monitoring should be archived electronically and be kept at least for two years after the end of the last crediting period. 100% of the data should be monitored if not indicated differently in the comments in the tables below.

#### Establishment of a HFC-23 balance

For each monitoring period  $m$ , a HFC-23 mass balance shall be established. The mass balance should include all HCFC-22 production lines that are eligible for crediting. The HFC-23 mass balance shall include the following information:

- The stock of HFC-23 stored at the beginning of the monitoring period (measured);
- HFC-23 generated in each production line  $k$  in the monitoring period (measured);
- HFC-23 sold to third parties in the monitoring period (measured/recorded);
- HFC-23 added to or taken from the stock of HFC-23 stored in the monitoring period (measured);



- HFC-23 sent to the inlet of each HFC-23 decomposition facility in the monitoring period (measured);
- HFC-23 released to the atmosphere through incomplete decomposition of HFC-23 in each HFC-23 decomposition facility in the monitoring period (measured);
- HFC-23 released to the atmosphere through venting or other sources (calculated based on the remainder of the mass balance);
- The stock of HFC-23 stored at the end of the monitoring period (calculated based on the stock of HFC-23 stored at the beginning of the monitoring period and any additions/subtractions to the stock of HFC-23 stored).

The mass balance shall be conducted for each calendar month as well as for the duration of the monitoring period  $m$  and shall be documented transparently in a table in the monitoring report.

### Data and parameters monitored

<b>Data / Parameter:</b>	$Q_{\text{HFC23,gen,k,m}}$
<b>Data unit:</b>	t HFC-23
<b>Description:</b>	Quantity of HFC-23 generated as a by-product in HCFC-22 production line $k$ in monitoring period $m$
<b>Source of data:</b>	Measurements by project participants
<b>Measurement procedures (if any):</b>	<p>The quantity of HFC-23 generated is a key parameter for the calculation of overall emission reductions. The quantity shall be measured separately for each HCFC-22 production line <math>k</math> that is eligible for crediting as per the procedure in step 1 under “Baseline emissions”. To measure this quantity accurately, two flow meters shall be used for each production line. The flow meters shall be installed in a manner which ensure that no HFC-23 from the production process can by-pass the flow meters.</p> <p>Where the flow meter readings differ by greater than twice their claimed accuracy (for example 10% if the accuracy is claimed to be <math>\pm 5\%</math>) then the reason for the discrepancy shall be investigated and the fault remedied.</p> <p>For the sake of conservativeness, for each meter reading <math>t</math>, the higher value of the two readings shall be used to estimate <math>Q_{\text{HFC23,gen,k,m}}</math>:</p> $Q_{\text{HFC23,gen,k,m}} = \sum_t \text{MAX}(Q_{\text{HFC23,gen,k,meter 1,t}}; Q_{\text{HFC23,gen,k,meter 2,t}})$ <p>The concentration of HFC-23 in the stream shall be measured by sampling using gas chromatography. The average flow rate should be multiplied with the average HFC-23 concentration in the stream to derive the amount of HFC-23 generated</p>



Monitoring frequency:	Flow measurements: continuously, meter integrated for at least every hour Concentration measurements: at least weekly in constant measurement intervals
QA/QC procedures:	A quality team should be formed to audit these procedure according to relevant national or international standards
Any comment:	The amount of HFC-23 generated shall be reported in monitoring reports for each production line separately and for each calendar month as well as for the entire monitoring period $m$

<b>Data / Parameter:</b>	$Q_{\text{HFC23,dec,d,inlet,m}}$
Data unit:	t HFC-23
Description:	Quantity of HFC-23 that is generated as a by-product in HCFC-22 production lines that are eligible for crediting and that is supplied to the inlet of the HFC-23 decomposition facility(ies) $d$ in monitoring period $m$
Source of data:	Measurements by project participants
Measurement procedures (if any):	<p>The quantity shall be measured separately for each HFC-23 decomposition facility <math>d</math> at the project activity site. To measure this quantity accurately, two flow meters shall be installed at the inlet of each HFC-23 decomposition facility. The flow meters shall be installed in a manner that they only measure the quantity of HFC-23 that is generated as a by-product in HCFC-22 production lines that are eligible for crediting.</p> <p>Where the flow meter readings differ by greater than twice their claimed accuracy (for example 10% if the accuracy is claimed to be <math>\pm 5\%</math>) then the reason for the discrepancy shall be investigated and the fault remedied.</p> <p>For the sake of conservativeness, for each meter reading <math>t</math>, the lower value of the two readings shall be used to estimate <math>Q_{\text{HFC23,dec,d,inlet,m}}</math>:</p> $Q_{\text{HFC23,dec,d,inlet,m}} = \sum_t \text{MIN}(Q_{\text{HFC23,dec,d,inlet,meter 1,t}}; Q_{\text{HFC23,dec,d,inlet,meter 2,t}})$ <p>The concentration of HFC-23 in the stream shall be measured by sampling using gas chromatography. The average flow rate should be multiplied with the average HFC-23 concentration in the stream to derive the amount of HFC-23 supplied to the inlet of the HFC-23 decomposition facility</p>
Monitoring frequency:	Flow measurements: continuously, meter integrated for at least every hour Concentration measurements: at least weekly in constant measurement intervals
QA/QC procedures:	A quality team should be formed to audit these procedure according to relevant national or international standards
Any comment:	The amount of HFC-23 supplied to the inlet of the HFC-23 decomposition facility shall be reported in monitoring reports for each HFC-23 decomposition facility separately and for each calendar month as well as for the entire monitoring period $m$



<b>Data / Parameter:</b>	$Q_{\text{HFC23,dec,d,outlet,m}}$
Data unit:	t HFC-23
Description:	Quantity of HFC-23 emitted at the outlet of the HFC-23 decomposition facility(ies) $d$ due to incomplete decomposition of HFC-23 in monitoring period $m$
Source of data:	Measurements by project participants
Measurement procedures (if any):	The quantity shall be measured separately for each HFC-23 decomposition facility $d$ at the project activity site  The concentration of HFC-23 in the stream shall be measured by sampling using gas chromatography. The average flow rate should be multiplied with the average HFC-23 concentration in the stream to derive the amount of HFC-23 emitted at the outlet of the HFC-23 decomposition facility
Monitoring frequency:	Flow measurements: continuously, meter integrated for at least every hour Concentration measurements: at least weekly in constant measurement intervals
QA/QC procedures:	A quality team should be formed to audit these procedure according to relevant national or international standards
Any comment:	The amount of HFC-23 emitted at the outlet of the HFC-23 decomposition facility shall be reported in monitoring reports for each HFC-23 decomposition facility separately and for each calendar month as well as for the entire monitoring period $m$

<b>Data / Parameter:</b>	$Q_{\text{HCFC22,k,m}}$
Data unit:	t HCFC-22
Description:	Amount of HCFC-22 produced in HCFC-22 production line $k$ in monitoring period $m$
Source of data:	Measurements by project participants
Measurement procedures (if any):	-
Monitoring frequency:	Continuously, aggregated monthly and for the duration of the monitoring period $m$
QA/QC procedures:	Cross-check measured data with sales data
Any comment:	If more than one HCFC-22 production line exists at the project activity site, the production in each production line shall be separately measured and reported



<b>Data / Parameter:</b>	$BE_{HFC23,REG,k,m}$
Data unit:	t HFC-23
Description:	Quantity of HFC-23 that is formed in HCFC-22 production line $k$ and that can be emitted to the atmosphere in monitoring period $m$ according to applicable regulations
Source of data:	Relevant regulations
Measurement procedures (if any):	-
Monitoring frequency:	For each monitoring report
QA/QC procedures:	-
Any comment:	-

<b>Data / Parameter:</b>	$W_{MIN,k,m}$
Data unit:	t HFC-23 / t HCFC-22
Description:	Minimum waste generation rate achieved by HCFC-22 production line $k$ up to monitoring period $m$
Source of data:	Plant records
Measurement procedures (if any):	Follow the guidelines in baseline emissions section
Monitoring frequency:	For the period before the crediting period starts: Average annual values shall be determined. During crediting period: Monthly values shall be determined
QA/QC procedures:	-
Any comment:	-

#### IV. REFERENCES

Midgley P.M. and D.A. Fisher, 1993: The Production and release to the atmosphere of chlorodifluoromethane (HCFC-22), *Atmos. Environ.*, 27A, 14, 2215-2223.

-----

Annex 1

**Example of HCFC-22 production process**

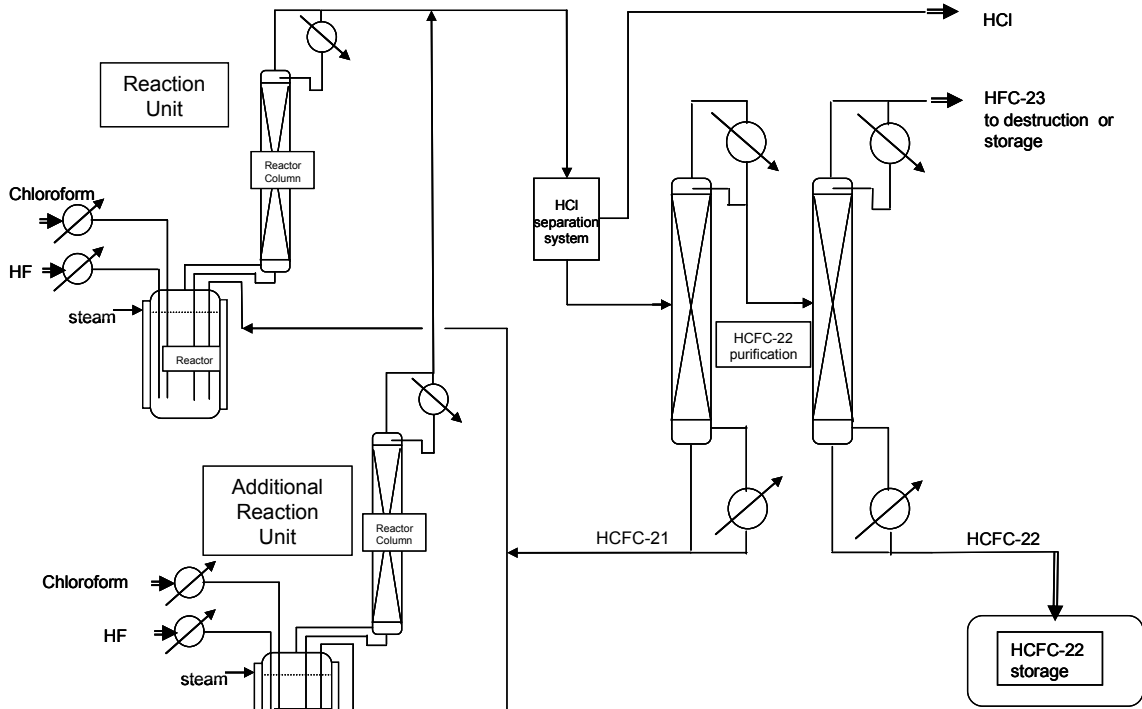

Illustration of an HCFC-22 Production Line with two Reaction Units, common Product Purification and Single Storage Facility

-----

**History of the document**

Version	Date	Nature of revision(s)
06.0.0	EB 65, Annex 10 25 November 2011	<p>Revision of the methodology to address issues identified by the methodologies panel in a report to the CDM Executive Board at its 46<sup>th</sup> meeting. The changes include, inter alia:</p> <ul style="list-style-type: none"> <li>• Change of the title from “Incineration of fluoroform (HFC-23) waste streams” to “Decomposition of fluoroform (HFC-23) waste streams”;</li> <li>• The introduction of a lower cap on the HFC-23 generation rate, i.e. the amount of HFC-23 formed per amount of HCFC-22 produced; and</li> <li>• The use of the average (and not maximum) historical HCFC-22 production to determine the amount of HCFC-22 that is eligible for crediting</li> <li>• Other changes, including a separation of project and baseline emissions, the provision of definitions for key terms, the determination of emissions for monitoring periods instead of years, a separate determination of baseline emissions for each production</li> </ul>



		line, modified provisions to account for the temporary storage of HFC-23, use of applicable tools to determine project emissions, additional guidance on an HFC-23 mass balance, provisions for the renewal of the crediting period, revised monitoring requirements and additional guidance to determine the historical waste generation rate. Due to the overall modification of this document, no highlights of the changes are provided.
05.2	3 December 2007	In equation (5), the variable HFC23(max,y) was replaced with HCFC(max,y) on the right hand side of the equation.
05.1	27 July 2007	Editorial revision to: <ul style="list-style-type: none"> <li>Amend the first row of the data monitoring table, to reflect the calibration requirements for the flow meters measuring the quantity of HFC-23 supplied to the destruction process (<math>q_{\text{HFC23y}}</math>) as stipulated in Section III of the baseline and monitoring methodology;</li> <li>Amend the footnote to table D.6, to reflect the correct frequency of calibration of the flow meters measuring the quantity of HFC-23 supplied to the destruction process.</li> </ul>
04	EB 24, Annex 3 12 May 2006	Revision to reflect an interpretation of “lower of the two readings” in the methodology in accordance with the Board’s guidance provided at its twenty-third meeting. With this revision the methodology clearly states that monthly recording of HFC23 flow is the sum of the lower of the two periodic readings taken by the two flow meters.
03	EB 19, Annex 4 13 May 2005	<ul style="list-style-type: none"> <li>The applicability conditions were modified to limit the methodology to existing HCFC22 production facilities which have at least three (3) years of operating history between beginning of the year 2000 and the end of the year 2004;</li> <li>The eligible production of HCFC-22 at the HCFC-22 production facility is capped to the maximum historical annual production level during any of the last three (3) years between beginning of the year 2000 and the end of the year 2004, including CFC production at swing plants adjusted appropriately to account for the different production rates of HCFC22 and CFCs;</li> <li>Clarification is made that the waste generation rate <math>w</math> should be estimated based on the three (3) most recent years of operation up to 2004. The requirements for measurement of this parameter are further clarified, including with regard to the use of a fluorine balance;</li> <li>The cap on the waste generation rate <math>w</math> is lowered from 4% to 3% (0.03 tonnes of HFC 23 produced per tonne of HCFC 22 produced).</li> <li>The requirement is specified that in case insufficient data is available for the calculation of HFC23 release for all three (3) most recent years of operation up to 2004, then the default value for <math>w</math> to be used is 1.5%;</li> <li>New requirements on HFC23 measurement during the crediting period are added in monitoring methodology.</li> </ul>
02	EB 15, para. 12 7 April 2004	<ul style="list-style-type: none"> <li>Clarification is provided on how the quantity of waste HFC23 destroyed is calculated;</li> <li>A footnote was added to clarify that the quantity of HFC23 used to calculate the waste generation rate <math>w</math> is the sum of HFC 23 recovered for sale plus the waste HFC 23;</li> <li>Several changes were made in the monitoring tables;</li> <li>Editorial revisions such as different nomenclature for some of the variables were made.</li> </ul>
01	26 September 2003	Initial adoption.
<b>Decision Class:</b> Regulatory <b>Document Type:</b> Standard <b>Business Function:</b> Methodology		