



Approved baseline and monitoring methodology AM0099

“Installation of a new natural gas fired gas turbine to an existing CHP plant”

I. SOURCE, DEFINITIONS AND APPLICABILITY

Sources

This baseline and monitoring methodology is based on elements from the following proposed new methodology:

- NM0344 “Introduction of a New Natural Gas Based Gas Turbine Cogeneration in Existing CHP Facilities Connected to the Electricity Grid” prepared by Tohoku Electric Power Co., Inc and Mitsubishi UFJ Morgan Stanley Securities Co., Ltd.;

This methodology also refers to the latest approved versions of the following tools:

- “Tool to calculate project or leakage CO₂ emissions from fossil fuel combustion”;
- “Tool for the demonstration and assessment of additionality”;
- “Tool to calculate the emission factor for an electricity system”;
- “Tool to determine the remaining lifetime of equipment”;
- “Tool to determine the baseline efficiency of thermal or electric energy generation systems”;
- “Tool to assess the validity of the original/current baseline and to update the baseline at the renewal of a crediting period”.

For more information regarding the proposed new methodology and the tools as well as their consideration by the Executive Board please refer to

<http://cdm.unfccc.int/methodologies/PAmethodologies/index.html>.

Selected approach from paragraph 48 of the CDM modalities and procedures

“Existing actual or historical emissions, as applicable”.

“Emissions from a technology that represents an economically attractive course of action, taking into account barriers to investment”

Definitions

For the purpose of this methodology, the following definitions apply:

Combined heat and power (CHP) plant is a plant designed to produce both heat and electricity from a single heat source.

Electricity consuming facility is a single industrial or commercial facility that is connected to the electric power grid and meets its electricity demand under the project activity with electricity from the



project activity power plant and, where applicable, in addition from (i) a captive power plant operated at the site of the electricity consuming facility and/or (ii) the electric power grid.¹

Captive power plant is a power plant operated at the site of the electricity consuming facility, including any back-up power generators.

Natural gas is a gas which is consisting primarily of methane and which is generated from: (i) Natural gas fields (non-associated gas), (ii) associated gas found in oil fields and/or (iii) gas captured from landfills. It may be blended up to 1% on a volume basis with gas from other sources, such as, *inter alia*, biogas generated in biodigesters, gas from coal mines, gas which is gasified from solid fossil fuels, etc.²

Heat recovery steam generator (HRSG) is an energy recovery heat exchanger that recovers heat from a hot gas stream. It produces steam that can be used in a process or used to drive a steam turbine. Supplementary fuel can be burned to increase the quality of the steam.

Applicability

This methodology applies to project activities that install a new natural-gas fired gas turbine at a site where there is an existing CHP plant and supply the electricity to the grid or an existing electricity consuming facility and waste heat to the existing CHP plant.

The methodology is applicable under the following conditions:

- The project activity is the installation of a new natural-gas fired gas turbine that supplies electricity: (i) to the electric power grid, and/or (ii) to an existing electricity consuming facility. The waste heat from the new gas turbine is used by a heat recovery steam generator (HRSG) to produce steam and which is then supplied to the steam header of the existing CHP plant. The steam from the HRSG is not directly supplied to final users/consumers;
- The existing CHP plant produced electricity and steam for at least three years prior to the implementation of the project activity. Electricity from the existing CHP plant was supplied (i) to the electric power grid, and/or (ii) to an existing electricity consuming facility. Steam from the existing CHP plant was supplied to the identified end users. This will continue during the project activity;
- Natural gas is used as main fuel in the project gas turbine. Small amounts of other start-up or auxiliary fuels can be used, but they shall not comprise more than 3% of total fuel used annually, on an energy basis;
- Natural gas is sufficiently available in the region or country, e.g. future natural gas based power capacity additions, comparable in size to the project activity, are not constrained by the use of natural gas in the project activity;³

¹ Grid is defined as per the “Tool to calculate the emission factor for an electricity system”.

² This limitation is included because the methodology does not provide procedures to estimate the GHG emissions associated with the production of gas from these other sources.

³ In some situations, there could be price-inelastic supply constraints (e.g. limited resources without possibility of expansion during the crediting period) that could mean that a project activity displaces natural gas that would otherwise be used elsewhere in an economy, thus leading to possible leakage. Hence, it is important for the project participants to document that supply limitations will not result in significant leakage as indicated here.



- The emission reduction due to the steam generated by HRSG is applicable up to the end of the lifetime of the existing boiler(s), if shorter than the crediting period. After this period, the baseline emissions for the steam generated by HRSG ($BE_{ST,y}$) and project emissions from the combustion of incremental fossil fuel due to reduced efficiency of existing boiler that results from operation at lower load ($PE_{SB,y}$) are considered as zero.

In addition, the applicability conditions included in the tools referred to above apply.

Finally, this methodology is only applicable if the most plausible baseline scenario, as identified per the section “Selection of the baseline scenario” hereunder, is:

- For electricity generation: Scenario E2 (electricity generation by the grid connected power plants or existing captive power plants;) and, in the case that electricity is supplied to an electricity consuming facility, in combination with scenarios C2, C3, C4 or C5; and
- For heat (steam) generation: Scenario H2 (steam is generated in the existing CHP plant);

II. BASELINE METHODOLOGY PROCEDURE

Project boundary

The **spatial extent** of the project boundary encompasses:

- The site of the project facility, including the existing CHP plant, new gas turbine and heat recovery steam generator;
- The heat supply system; and
- All power plants connected physically to the baseline grid as defined in the “Tool to calculate emission factor for an electricity system”.

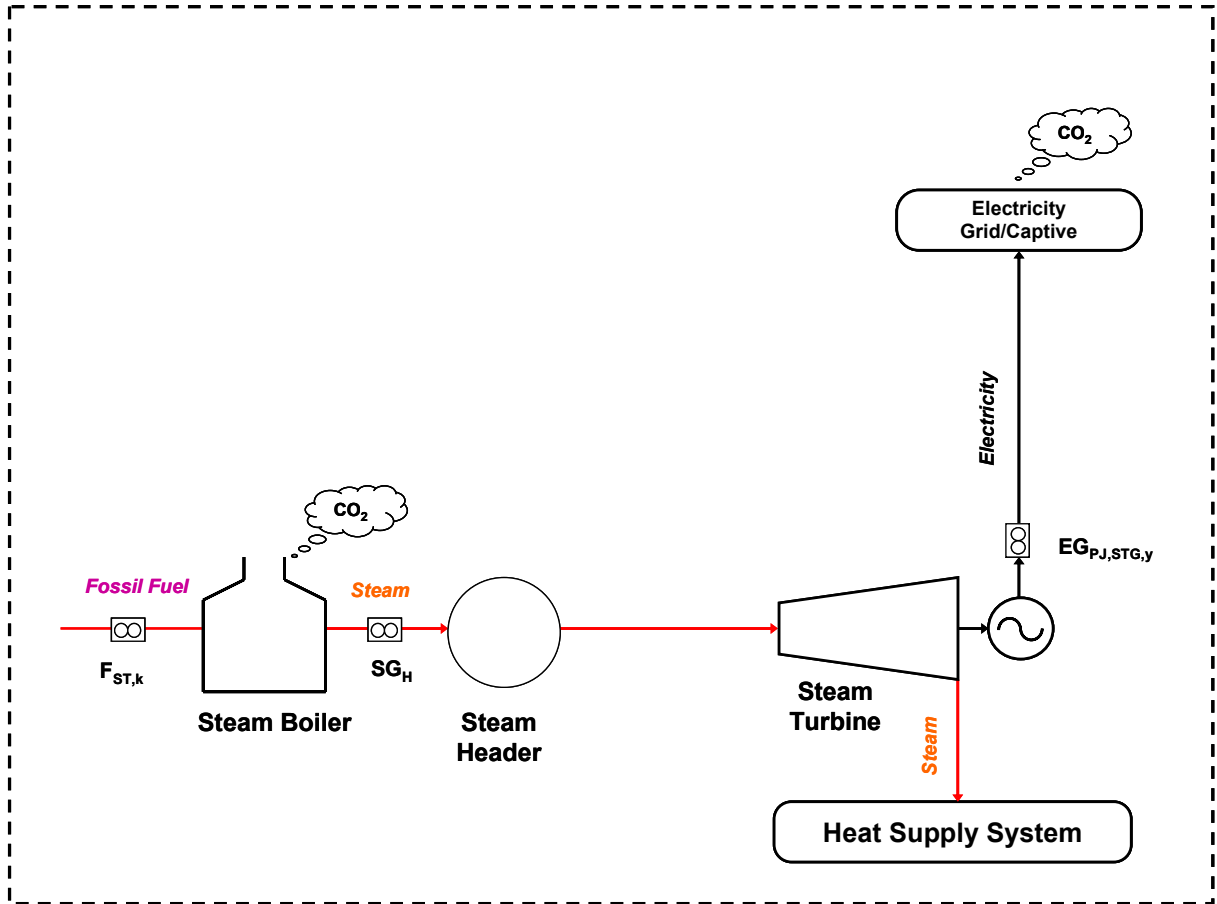

Figure 1: Baseline boundary

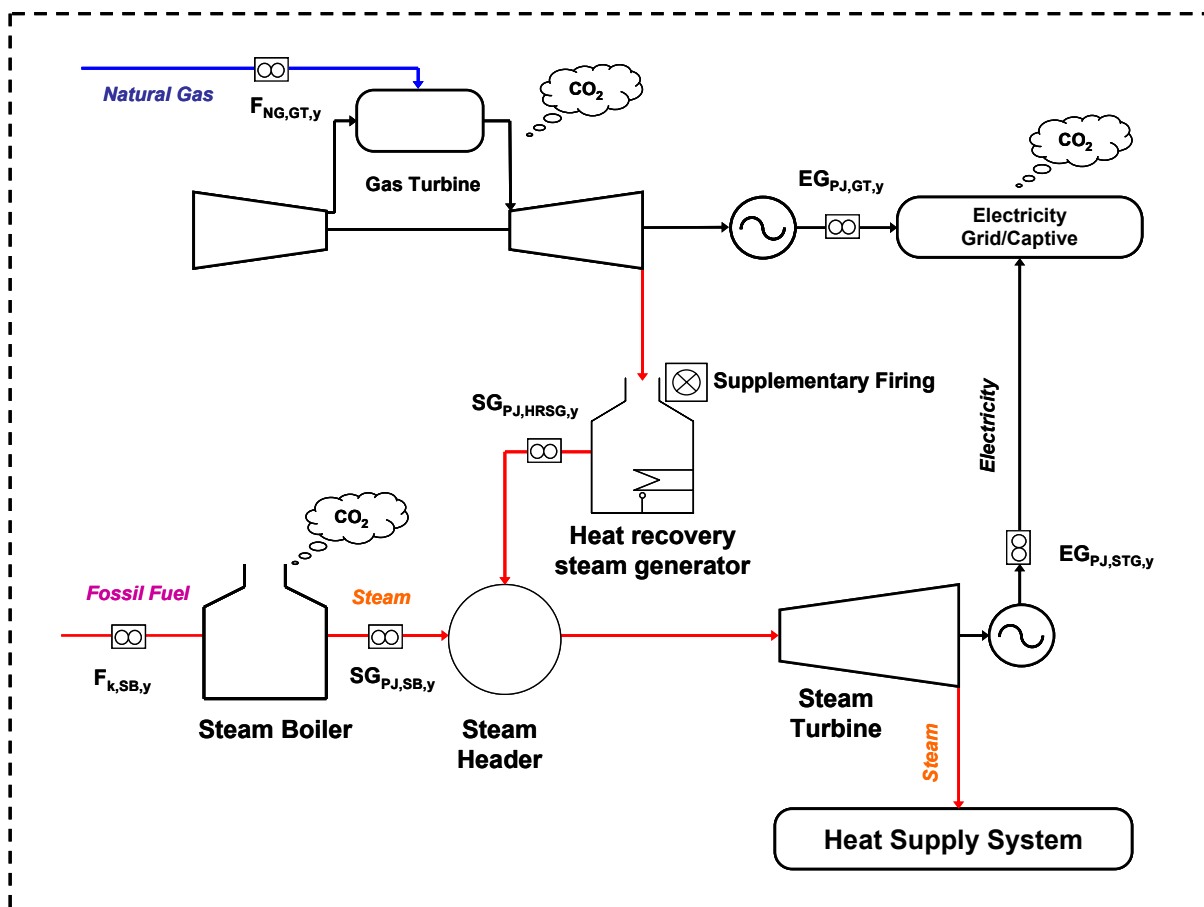

Figure 2: Project Boundary

The greenhouse gases included in or excluded from the project boundary are shown in Table 1.

Table 1: Emissions sources included in or excluded from the project boundary

	Source	Gas	Included?	Justification / Explanation
Baseline	Combustion of fossil fuels to produce steam for the existing steam supply head in the existing boilers	CO ₂	Yes	Main emission source
		CH ₄	No	Excluded for simplification. This is conservative
		N ₂ O	No	Excluded for simplification. This is conservative
	Combustion of fossil fuels to produce electricity in the grid or in the captive power plants	CO ₂	Yes	Main emission source
		CH ₄	No	Excluded for simplification. This is conservative
		N ₂ O	No	Excluded for simplification. This is conservative



	Source	Gas	Included?	Justification / Explanation
Project activity	Combustion of natural gas to produce electricity in the new gas turbine	CO ₂	Yes	Main emission source
		CH ₄	No	Excluded for simplification. This emission source is assumed to be very small
		N ₂ O	No	Excluded for simplification. This emission source is assumed to be very small
	Combustion of supplementary fuels	CO ₂	Yes	May be an important emission source
		CH ₄	No	Excluded for simplification. This emission source is assumed to be very small
		N ₂ O	No	Excluded for simplification. This emission source is assumed to be very small
	Combustion of incremental fossil fuel associated with possible reduced efficiency in the existing boilers	CO ₂	Yes	May be an important emission source
		CH ₄	No	Excluded for simplification. This emission source is assumed to be very small
		N ₂ O	No	Excluded for simplification. This emission source is assumed to be very small

Selection of the baseline scenario

The project proponents shall select the most plausible baseline scenario through the following four-step procedure:

Step 1: Identify all plausible alternative scenarios

Identify realistic alternative scenarios that are available to the project participants and that provide outputs or services with comparable quality, properties and application areas as the proposed CDM project activity.

The alternative scenarios should specify:

- How electric power would be generated in the absence of the CDM project activity;
- If applicable, how electricity would be supplied to the existing electricity consuming facility;
- How heat (steam) would be generated in the absence of the CDM project activity.

The alternatives should also include possibilities for using alternative fuels or fuel switch at the existing installation. Analysis of fuel availability has to be provided during determination with proper justification.

Electricity Generation

For electricity generation, the alternative scenarios should include, but not be limited to, *inter alia*:

- E1: The proposed project activity not undertaken as a CDM project activity (electricity generation by the gas turbine);
- E2: Electricity generation by the grid connected power plants or existing captive power plants;
- E3: Electricity generation by new fossil fuel based power plant(s);



- E4: Electricity generation by new fossil fuel based steam turbine cogeneration facility;
- E5: Electricity generation by new renewable energy or biomass-fired power plant(s);
- E6: Electricity generation by new renewable energy or biomass-fired cogeneration facility.

These alternatives do not need to consist solely of power plants of the same capacity, load factor and operational characteristics (i.e. several smaller plants, or the share of a larger plant may be a reasonable alternative to the project activity), however they should deliver similar services (e.g. peak-vs. base-load power). Ensure that all relevant power plant technologies that have recently been constructed or are under construction in the region or are being planned by the project participants are included as plausible alternatives.

If the project power plant supplies electricity to an electricity consuming facility, alternatives to be analyzed for this facility should include, *inter alia*:

- C1: The project activity not implemented as a CDM project;
- C2: The construction of one or several captive power plants at the site of the electricity consuming facility;
- C3: The continued operation of one or several captive power plants at the site of the electricity consuming facility;
- C4: Purchase of electricity from the grid;
- C5: A combination of one or several new and/or existing captive power plants operated at the site of the electricity consuming facility and purchase of electricity from the grid;
- C6: Purchase of electricity from another dedicated off-site power plant.

In considering these scenarios, it should be ensured that the same service is provided to the electricity consuming facility (i.e. the electricity demand of the facility should be met in all scenarios).

Heat (Steam) Generation

For heat (steam) generation, the alternative scenarios should include, but not be limited to, *inter alia*:

- H1: The proposed project activity not undertaken as a CDM project activity (steam is generated in the HRSG);
- H2: The continuation of steam generation in the existing CHP plant;
- H3: Steam is generated in a new steam turbine cogeneration facility;
- H4: Steam is generated in new fossil fuel fired boilers;
- H6: Steam is generated in a new renewable energy or biomass-fired boilers;
- H7: Steam is generated in a new renewable energy or biomass-fired cogeneration facility;
- H8: Steam is generated in specific off-site plant(s).

A clear description of each baseline scenario alternative, including information on the technology, such as the efficiency and technical lifetime, shall be provided in the CDM-PDD.

If one or more scenarios are excluded, an appropriate explanation and documentation to support the exclusion of such scenario shall be provided in the CDM-PDD.



If the project power plant supplies electricity to an electricity consuming facility, realistic combinations of scenarios for power generation by the project participants (E) and consumption of power by the electricity consuming facility (C) should be considered in the subsequent steps.

Step 2: Eliminate alternatives that do not comply with mandatory laws and regulations:

Eliminate alternatives that are not in compliance with all applicable mandatory laws and regulations by applying Sub-Step 1b of the latest approved version of the “Tool for demonstration and assessment of additionality”.

Step 3: Eliminate alternatives that face prohibitive barriers

Scenarios that face prohibitive barriers should be eliminated by applying Step 3 of the latest approved version of the “Tool for demonstration and assessment of additionality”.

Step 4: Identify the economically most attractive alternative

The economically most attractive alternative is identified using an investment comparison analysis, by applying Step 2 (Option II) of the latest approved version of the “Tool for the demonstration and assessment of additionality”. Calculate a suitable financial indicator for all alternatives remaining after Step 1. Include all (i) relevant costs (including, for example, the investment cost, fuel costs and operation and maintenance costs), (ii) revenues (including subsidies/fiscal incentives,⁴ ODA, etc, where applicable) and, as appropriate, (iii) non-market costs and benefits in the case of public investors. The alternative that has the best financial indicator should be pre-selected as the most plausible baseline scenario.

Guidance on estimation of the remaining lifetime of existing boiler

The remaining lifetime of the existing boiler should be estimated using latest approved version of the “Tool to determine the remaining lifetime of equipment”.

Additionality

The demonstration of additionality should be conducted using the “Tool for demonstration and assessment of additionality”.

While applying the Step 2 (Investment Analysis) of the tool, the following guidance should be followed:

- The investment analysis is conducted for both components (power and heat) in combination. All the costs directly related to the project should be included in the analysis;
- In case of Sub-step 2b, use Option III (benchmark analysis).

Baseline emissions

The baseline emissions are the sum of emissions from electricity generation and emissions from steam generation.

$$BE_y = BE_{EL,y} + BE_{ST,y} \quad (1)$$

⁴ Note the guidance by EB 22 on national and/or sectoral policies and regulations.



Where:

- BE_y = Baseline emissions in year y (tCO₂e)
 $BE_{EL,y}$ = Baseline emissions for the electricity generated by the new gas turbine in year y (tCO₂e)
 $BE_{ST,y}$ = Baseline emissions for the steam generated by HRSG in year y (tCO₂e)

Baseline emissions for the electricity generated by the gas turbine ($BE_{EL,y}$)

Baseline emissions for the electricity generated by the gas turbine are calculated by multiplying the quantity of electricity generated by the gas turbine that is fed into the grid and/or supplied to the electricity consuming facility with a CO₂ emission factor for electricity generation in the baseline.

$$BE_{EL,y} = EG_{PJ,GT,y} \times EF_{BL,CO_2,y} \quad (2)$$

Where:

- $BE_{EL,y}$ = Baseline emissions for the electricity generated by the new gas turbine in year y (tCO₂e)
 $EG_{PJ,GT,y}$ = Quantity of electricity generated by the new gas turbine that is fed into the grid and/or supplied to the electricity consuming facility in year y (MWh)
 $EF_{BL,CO_2,y}$ = CO₂ emission factor for electricity generation in the baseline in year y (tCO₂/MWh)

Determination of $EF_{BL,CO_2,y}$

For construction of large new power capacity additions under the CDM, there is a considerable uncertainty relating to which type of other power generation is substituted by the power generation of the project plant. As a result of the project, the application of an alternative power generation technology(s) could be avoided, or the construction of a series of other power plants could simply be delayed. Furthermore, if the project were installed sooner than these other projects might have been constructed, its near-term impact could be largely to reduce electricity generation in existing plants. This depends on many factors and assumptions (e.g. whether there is a supply deficit) that are difficult to determine and that change over time. Similarly, in the case of new power plants supplying electricity to an electricity consuming facility which is also connected to the electric power grid, there is high level of uncertainty on whether the new power plant would displace an existing or new to be built captive power plant or electricity from the electric power grid. In order to address this uncertainty in a conservative manner, project participants shall use for the parameter $EF_{BL,CO_2,y}$ the lowest emission factor in tCO₂/MWh among the following three options:

- Option 1: The build margin, calculated according to the latest approved version of the “Tool to calculate emission factor for an electricity system” ($EF_{BL,CO_2,y} = EF_{grid,BM,y}$);
- Option 2: The combined margin, calculated according to the latest approved version of the “Tool to calculate the emission factor for an electricity system”, using a 50/50 Operating Margin/Build Margin (OM/BM) weight ($EF_{BL,CO_2,y} = EF_{grid,CM,y}$); or
- Option 3: The lowest among the emission factors of (a) the technology and fuel, identified as the most likely baseline scenario under “Identification of the baseline scenario” above, and, if



applicable, (b) the emission factor of existing or new captive power plant(s)⁵ (i.e. scenarios C2, C3 or C5). The emission factor is to be calculated as follows ($EF_{BL,CO_2,y} = EF_{BL,Tech,CO_2}$):

$$EF_{BL,Tech,CO_2} = \frac{CEF_{BL}}{\eta_{BL}} \times 3.6 \quad (3)$$

Where:

$EF_{BL,Tech,CO_2}$ = Emission factor of the baseline technology and fuel (tCO₂/MWh)

CEF_{BL} = Carbon emission factor of the baseline fuel (tCO₂/TJ)

η_{BL} = The energy efficiency of the baseline technology (ratio)

3.6 = Conversion factor from GJ to MWh (GJ/MWh)

If Option 3 is selected, the determination of $EF_{BL,CO_2,y}$ is to be made once at the validation stage based on an *ex ante* assessment. In the case of existing captive power plants, the parameter η_{BL} should be determined using the latest approved version of the “Tool to determine the baseline efficiency of thermal or electric energy generation systems”. The tool should be used to determine a constant efficiency and not a load-efficiency function. In the case of new power plants, the parameter η_{BL} corresponds to the maximum efficiency of the baseline technology at the optimal operating conditions, as supported by the manufacturer of this technology.

If either Option 1 (BM) or Option 2 (CM) are selected, $EF_{BL,CO_2,y}$ is to be monitored *ex post* as described in “Tool to calculate the emission factor for an electricity system”.

Baseline emissions for the steam generated by HRSG ($BE_{ST,y}$)

Baseline emissions for the steam generated by HRSG in year y ($BE_{ST,y}$) is calculated as follows:

$$BE_{ST,y} = SG_{BL,y} \times SEF_{BL} \quad (4)$$

Where:

$BE_{ST,y}$ = Baseline emissions for the steam generated by HRSG in year y (tCO₂e)

$SG_{BL,y}$ = Steam generated by the project activity in year y eligible for emissions reductions (TJ)

SEF_{BL} = Baseline CO₂ emission factor for steam (tCO₂e/TJ)

Determination of steam generated by the project activity eligible for emissions reductions

$$SG_{BL,y} = \min(SG_{PJ,HRSG,y}, SG_H) \quad (5)$$

Where:

$SG_{BL,y}$ = Steam generated by the project activity in year y eligible for emissions reductions (TJ)

$SG_{PJ,HRSG,y}$ = Steam generated by the project facility from heat recovery steam generator (HRSG) in year y (TJ)

SG_H = Average historical amount of steam generation of the existing steam boiler(s) prior

⁵ In case that more than one captive power plant exists at the site of the electricity consuming facility, the lowest emission factor among these shall be used.



to the implementation of the project activity (TJ), calculated as the average annual steam generation in the most recent three years prior to the start of the project activity.

Determination of baseline CO₂ emission factor for steam

$$SEF_{BL} = \frac{\sum_k (CEF_k \times FC_{ST,k})}{SG_H} \quad (6)$$

Where:

- SEF_{BL} = Baseline CO₂ emission factor for steam (tCO₂e/TJ)
 CEF_k = Carbon emission factor of fossil fuel k used by the existing CHP plant to generate steam in the baseline scenario (tCO₂/TJ)
 $FC_{ST,k}$ = Consumption of fuel k by the existing CHP plant to generate steam in the baseline scenario (TJ)
 SG_H = Average historical amount of steam generation of the existing CHP plant prior to the implementation of the project activity (TJ), calculated as the average annual steam generation in the most recent three years prior to the start of the project activity.

The consumption of fuel k to generate steam in the baseline scenario is calculated as:

$$FC_{ST,k} = F_{ST,k} \times NCV_k \quad (7)$$

Where:

- $FC_{ST,k}$ = Consumption of fuel k by the existing plant to generate steam in the baseline scenario (TJ)
 $F_{ST,k}$ = The average annual amount of fuel k used to generate steam at the existing CHP plant during the most recent three years previous to the implementation of the project activity (mass or volume units)
 NCV_k = Net calorific value of fuel k used to generate steam at the existing CHP plant during the most recent three years previous to the implementation of the project activity (TJ/mass or volume units).

Project emissions

Project emissions include the emissions from the use of fossil fuel in the project activity; including both in new natural gas turbine and existing fossil fuel fired boiler(s).

Project emissions are calculated as follows:

$$PE_y = PE_{FC,y} + PE_{SB,y} \quad (8)$$

Where:

- PE_y = Project emissions in year y (tCO₂e)
 $PE_{FC,y}$ = Project emissions from fossil fuel combustion in year y (tCO₂e)
 $PE_{SB,y}$ = Project emissions from the combustion of incremental fossil fuel due to reduced efficiency of existing boilers that results from operation at lower load (tCO₂e)

**Project emissions from fossil fuel consumption ($PE_{FC,y}$)**

Project emissions from fossil fuel combustion in year y ($PE_{FC,y}$) are calculated using the latest approved version of the “Tool to calculate project or leakage CO₂ emissions from fossil fuel combustion”, where the sources j in the tool correspond to all sources of fossil fuel consumption by the project activity, including new natural gas turbine and supplementary fossil fuels fired in the HRSG. All emission sources should be documented transparently in the CDM-PDD.

Project emissions from the combustion of incremental fossil fuel due to reduced efficiency of existing boilers that results from operation at lower load ($PE_{SB,y}$)

Project emissions from the combustion of incremental fossil fuel due to reduced efficiency of existing boilers that results from operation at lower load ($PE_{SB,y}$) are calculated as:

$$PE_{SB,y} = \max[0, (SEF_y - SEF_{BL}) \times SG_{PJ,SB,y}] \quad (9)$$

Where:

- $PE_{SB,y}$ = Project emissions from the combustion of incremental fossil fuel due to reduced efficiency of existing boilers that results from operation at lower load (tCO₂e)
 SEF_y = Emission factor for steam in year y (tCO₂/TJ)
 SEF_{BL} = Baseline emission factor for steam (tCO₂/TJ)
 $SG_{PJ,SB,y}$ = Steam generated in the project scenario by the existing steam boilers in year y (TJ)

Even if $SEF_y - SEF_{BL}$ is negative in any year, for the sake of conservativeness, $PE_{SB,y}$ is considered equal to zero.

Determination of the emission factor for steam in year y (SEF_y)

The emission factor for steam in year y (SEF_y) shall be calculated as:

$$SEF_y = \frac{\sum_k (CEF_{k,y} \times FC_{k,SB,y})}{SG_{PJ,SB,y}} \quad (10)$$

Where:

- SEF_y = Emission factor for steam in year y (tCO₂/TJ)
 $CEF_{k,y}$ = Carbon emission factor of fuel k used by the existing plant to generate steam in year y (tCO₂/TJ)
 $FC_{k,SB,y}$ = Fuel k consumption by the existing steam boilers in year y (TJ)
 $SG_{PJ,SB,y}$ = Steam generated in the project scenario by the existing steam boilers in year y (TJ)

The consumption of fuel k to generate steam in the baseline scenario is calculated as:

$$FC_{k,SB,y} = F_{k,SB,y} \times NCV_{k,y} \quad (11)$$

Where:

- $FC_{k,SB,y}$ = Fuel k consumption by the existing steam boilers in year y (TJ)
 $F_{k,SB,y}$ = The amount of fuel k consumed by the existing steam boilers in year y (mass or volume units).



$NCV_{k,y}$ = Net calorific value of fuel k in year y (TJ/mass or volume units)

Leakage

Leakage may result from fuel extraction, processing, liquefaction, transportation, re-gasification and distribution of fossil fuels outside of the project boundary. This leakage includes mainly (i) fugitive CH₄ emissions, (ii) CO₂ emissions from the process of CO₂ removal from the raw natural gas stream in order to upgrade the natural gas to the required market conditions, and (iii) CO₂ emissions from associated fuel combustion and flaring. In this methodology, the following leakage emission sources shall be considered:

- Fugitive CH₄ emissions associated with the extraction, processing, liquefaction, transportation, re-gasification and distribution of the additional volumes of natural gas used in the project plant and, in the baseline scenario, in power plants connected to the grid;
- CO₂ emissions from the process of CO₂ removal from the raw natural gas stream in order to upgrade the natural gas to the required market conditions; and
- In the case that Liquefied Natural Gas (LNG) is used in the project plant, CO₂ emissions are to be accounted for due to fuel combustion/electricity consumption associated with the liquefaction, transportation, re-gasification and compression into a natural gas transmission or distribution system for the additional volumes of LNG.

Thus, leakage emissions are calculated as follows:

$$LE_y = LE_{CH_4,y} + LE_{CO_2,y} + LE_{LNG,CO_2,y} \quad (12)$$

Where:

LE_y = Leakage emissions (tCO₂e)

$LE_{CH_4,y}$ = Leakage emissions due to fugitive upstream CH₄ emissions in year y (tCO₂e)

$LE_{CO_2,y}$ = Leakage emissions due to the removal of CO₂ from the raw natural gas stream in year y (tCO₂e)

$LE_{LNG,CO_2,y}$ = Leakage emissions due to fossil fuel combustion/electricity consumption associated with the liquefaction, transportation, re-gasification and compression of LNG into a natural gas transmission or distribution system in year y (tCO₂e)

To the extent that upstream emissions occur in Annex I countries that have ratified the Kyoto Protocol, from 1 January 2008 onwards, these emissions should be excluded, if technically possible, in the leakage calculations.

Fugitive methane emissions ($LE_{CH_4,y}$)

For the purpose of estimating fugitive CH₄ emissions, project participants should multiply the quantity of natural gas additionally consumed by the project in year y with an emission factor for fugitive CH₄ emissions ($EF_{NG,upstream,CH_4}$) from natural gas consumption and subtract the emissions occurring from fossil fuels used in the absence of the project activity, as follows:

$$LE_{CH_4,y} = [(F_{NG,y} - F_{ST,NG}) \times NCV_{NG,y} \times EF_{NG,upstream,CH_4} - EG_{PJ,GT,y} \times EF_{BL,upstream,CH_4,y}] \times GWP_{CH_4} \quad (13)$$



Where:

$LE_{CH_4,y}$	= Leakage emissions due to fugitive upstream CH ₄ emissions in year y (tCO ₂ e)
$F_{NG,y}$	= Quantity of natural gas combusted in the project plant in year y (m ³)
$F_{ST,NG}$	= The average annual amount of natural gas used to generate steam during the most recent three years previous to the implementation of the project activity (m ³)
$NCV_{NG,y}$	= Average net calorific value of the natural gas combusted during the year y (TJ/m ³)
$EF_{NG,upstream,C}$	= Emission factor for upstream fugitive methane emissions of natural gas from production, transportation, distribution, and, in the case of LNG, liquefaction, transportation, re-gasification and compression into a transmission or distribution system (tCH ₄ /TJ)
$H4$	
$EG_{PJ,GT,y}$	= Quantity of electricity generated by the gas turbine that is fed into the grid and/or supplied to the electricity consuming facility in year y (MWh)
$EF_{BL,upstream,C}$	= Emission factor for upstream fugitive methane emissions occurring in the absence of the project activity power plant in year y (tCH ₄ /MWh)
$H4,y$	
GWP_{CH_4}	= Global warming potential of methane valid for the relevant commitment period (tCO ₂ e/tCH ₄)

Determination of $F_{NG,y}$

$$F_{NG,y} = F_{NG,GT,y} + F_{NG,SB,y} \quad (14)$$

Where:

$F_{NG,y}$	= Quantity of natural gas combusted in the project plant in year y (m ³)
$F_{NG,GT,y}$	= Natural gas consumption by the project gas turbine generator in year y (m ³)
$F_{NG,SB,y}$	= Natural gas consumption by the existing steam boilers in year y (m ³)

The emission factor for upstream fugitive CH₄ emissions occurring in the absence of the project activity ($EF_{BL,upstream,CH_4,y}$) should be calculated consistent with the baseline emission factor (EF_{BL,CO_2}) selected above, as follows:

Option I: Build Margin

$$EF_{BL,upstream,CH_4,y} = \frac{\sum_j \sum_k FF_{j,k,y} \times NCV_{j,k,y} \times EF_{k,upstream,CH_4}}{\sum_j EG_{j,y}} \quad (15)$$

Option II: Combined Margin

$$EF_{BL,upstream,CH_4,y} = 0.5 \times \frac{\sum_j \sum_k FF_{j,k,y} \times NCV_{j,k,y} \times EF_{k,upstream,CH_4}}{\sum_j EG_{j,y}} + 0.5 \times \frac{\sum_i \sum_k FF_{i,k,y} \times NCV_{i,k,y} \times EF_{k,upstream,CH_4}}{\sum_i EG_{i,y}} \quad (16)$$



Where:

$EF_{BL,upstream,C}$	= Emission factor for upstream fugitive methane emissions occurring in the absence of the project activity power plant in year y (tCH ₄ /MWh)
$H4,y$	= Plants included in the build margin
j	= Quantity of fuel type k (a coal or oil type) combusted in power plant j included in the build margin in year y (mass or volume units)
$FF_{j,k,y}$	= Average net calorific value of fuel type k (a coal or oil type) combusted in power plant j included in the build margin in year y (TJ/mass or volume units)
$NCV_{j,k,y}$	= Emission factor for upstream fugitive methane emissions from production of the fuel type k (a coal or oil type) (tCH ₄ /TJ)
$EF_{k,upstream,CH4}$	= Electricity generation in the plant j included in the build margin in year y (MWh)
$EG_{j,y}$	= Plants included in the operating margin
i	= Quantity of fuel type k (a coal or oil type) combusted in power plant i included in the operating margin in year y (mass or volume units)
$FF_{i,k,y}$	= Average net calorific value of fuel type k (a coal or oil type) combusted in power plant i included in the operating margin in year y (TJ/mass or volume units)
$NCV_{i,k,y}$	= Electricity generation in the plant i included in the operating margin in year y (MWh)
$EG_{i,y}$	

Where reliable and accurate national data on fugitive CH₄ emissions associated with the production, and in case of natural gas, the transportation and distribution of the fuels is available, project participants should use this data to determine average emission factors by dividing the total quantity of CH₄ emissions by the quantity of fuel produced or supplied respectively. Where such data is not available, project participants should use the default values provided in Table 2 below.

Note that the emission factor for fugitive upstream emissions for natural gas ($EF_{NG,upstream,CH4}$) should include fugitive emissions from production, processing, transport and distribution of natural gas, as indicated in the Table 2 below. Where default values from this table are used, the natural gas emission factors for the location of the project activity should be used. The US/Canada values may be used in cases where it can be shown that the relevant system element (gas production and/or processing/transmission/distribution) is predominantly of recent vintage and built and operated to international standards.

Since the fugitive upstream emissions for coal depends on the source (underground or surface mines), project participants should use the emission factor that corresponds to the predominant source (underground or surface) currently used by coal-based power plants in the region.

Note further that in case of coal the emission factor is provided based on a mass unit and needs to be converted in an energy unit, taking into account the net calorific value of the coal. Moreover, all values used from Table 2 are to be converted to the appropriate units in order to be correctly used in the equations provided in this methodology.

**Table 2: Default emission factors for fugitive CH₄ upstream emissions**

Activity	Unit	Default emission factor	Reference for the underlying emission factor range in Volume 3 of the 1996 Revised IPCC Guidelines
Coal			
Underground mining	t CH ₄ / kt coal	13.4	Equations 1 and 4, p. 1.105 and 1.110
Surface mining	t CH ₄ / kt coal	0.8	Equations 2 and 4, p.1.108 and 1.110
Oil			
Production	t CH ₄ / PJ	2.5	Tables 1-60 to 1-64, p. 1.129 - 1.131
Transport, refining and storage	t CH ₄ / PJ	1.6	Tables 1-60 to 1-64, p. 1.129 - 1.131
Total	t CH ₄ / PJ	4.1	
Natural gas			
USA and Canada			
Production	t CH ₄ / PJ	72	Table 1-60, p. 1.129
Processing, transport and distribution	t CH ₄ / PJ	88	Table 1-60, p. 1.129
Total	t CH ₄ / PJ	160	
Eastern Europe and former USSR			
Production	t CH ₄ / PJ	393	Table 1-61, p. 1.129
Processing, transport and distribution	t CH ₄ / PJ	528	Table 1-61, p. 1.129
Total	t CH ₄ / PJ	921	
Western Europe			
Production	t CH ₄ / PJ	21	Table 1-62, p. 1.130
Processing, transport and distribution	t CH ₄ / PJ	85	Table 1-62, p. 1.130
Total	t CH ₄ / PJ	105	
Other oil exporting countries / Rest of world			
Production	t CH ₄ / PJ	68	Table 1-63 and 1-64, p. 1.130 and 1.131
Processing, transport and distribution	t CH ₄ / PJ	228	Table 1-63 and 1-64, p. 1.130 and 1.131
Total	t CH ₄ / PJ	296	
Note: The emission factors in this table have been derived from IPCC default Tier 1 emission factors provided in Volume 3 of the 1996 Revised IPCC Guidelines, by calculating the average of the provided default emission factor range.			

Upstream emissions due to CO₂ removal from raw natural gas stream (LE_{CO₂,y})

In processing natural gas, CO₂ contained in the raw gas is removed and usually vented to the atmosphere. The CO₂ is removed to upgrade the gas to specifications required for commercial application. Emissions from venting of the CO₂ only need to be estimated if the average CO₂ content of the raw gas, which is processed in the gas processing plants supplying the applicable gas transmission and distribution system, is higher than 5% on a volume basis. In this case, the leakage emissions LE_{CO₂,y} are to be estimated as follows:

$$LE_{CO_2,y} = (F_{NG,y} - F_{ST,NG}) \times \frac{r_{CO_2}}{1 - r_{CO_2}} \times \rho_{CO_2} \quad (17)$$

Where:

- LE_{CO₂,y} = Leakage emissions due to the removal of CO₂ from the raw natural gas stream in year y (tCO₂)
- F_{NG,y} = Quantity of natural gas combusted in the project plant in year y (m³)
- F_{ST,NG} = The average annual amount of natural gas used to generate steam during the most recent three years previous to the implementation of the project activity (m³).
Obtained from the project participant.



r_{CO_2} = Average CO₂ content in the raw natural gas stream on volume basis (ratio)
 ρ_{CO_2} = Density of CO₂ under standard conditions (tonnes/m³)

CO₂ emissions from LNG ($LE_{LNG,CO_2,y}$)

Where applicable, CO₂ emissions from fuel combustion/electricity consumption associated with the liquefaction, transportation, re-gasification and compression of LNG into a natural gas transmission or distribution system should be estimated by multiplying the quantity of natural gas combusted in the project with an appropriate emission factor, as follows:

$$LE_{LNG,CO_2,y} = (F_{NG,y} - F_{ST,NG}) \times NCV_{NG,y} \times EF_{CO_2,upstream,LNG} \quad (18)$$

Where:

$LE_{LNG,CO_2,y}$ = Leakage emissions due to fossil fuel combustion/electricity consumption associated with the liquefaction, transportation, re-gasification and compression of LNG into a natural gas transmission or distribution system in year y (tCO₂e)
 $F_{NG,y}$ = Quantity of natural gas combusted in the project plant in year y (m³)
 $F_{ST,NG}$ = The average annual amount of fuel natural gas used to generate steam during the most recent three years previous to the implementation of the project activity (m³). Obtained from the project participant.
 $NCV_{NG,y}$ = Average net calorific value of natural gas combusted in year y (TJ/m³)
 $EF_{CO_2,upstream,LNG}$ = Emission factor for upstream CO₂ emissions due to fossil fuel combustion/electricity consumption associated with the liquefaction, transportation, re-gasification and compression of LNG into a natural gas transmission or distribution system (tCO₂e/TJ)

Where reliable and accurate data on upstream CO₂ emissions due to fossil fuel combustion/electricity consumption associated with the liquefaction, transportation, re-gasification and compression of LNG into a natural gas transmission or distribution system is available, project participants should use this data to determine an average emission factor. Where such data is not available, project participants may assume a default value of 6 tCO₂e/TJ as a rough approximation. (This value has to be converted to the appropriate units in order to be correctly used in the equations provided in the methodology). Where total net leakage effects are negative ($LE_y < 0$), project participants should assume $LE_y = 0$.

Emission reductions

Emission reductions are calculated as follows:

$$ER_y = BE_y - PE_y - LE_y \quad (19)$$

Where:

ER_y = Emission reductions in year y (tCO₂e)
 BE_y = Baseline emissions in year y (tCO₂e)
 PE_y = Project emissions in year y (tCO₂e)
 LE_y = Leakage emissions in year y (tCO₂e)



Changes required for methodology implementation in 2nd and 3rd crediting periods

Refer to the latest approved version of the “Tool to assess the validity of the original/current baseline and to update the baseline at the renewal of a crediting period”.

Data and parameters not monitored

Data / Parameter:	SG_H
Data unit:	TJ
Description:	Average historical amount of steam generation of the existing CHP plant prior to the implementation of the project activity
Source of data:	Project participants
Measurement procedures (if any):	The average annual steam generation in the most recent three years prior to the start of the project activity
Any comment:	-

Data / Parameter:	CEF_k										
Data unit:	tCO ₂ /TJ										
Description:	Carbon emission factor of fuel k used by the existing plant to generate steam in the baseline scenario										
Source of data:	<p>The following data sources may be used if the relevant conditions apply:</p> <table border="1"> <thead> <tr> <th>Data source</th> <th>Conditions for using the data source</th> </tr> </thead> <tbody> <tr> <td>(a) Values provided by the fuel supplier in invoices</td> <td>This is the preferred source in case existing plant(s) are identified as the most likely baseline scenario</td> </tr> <tr> <td>(b) measurements by the project participants</td> <td>Applicable to existing captive power plants if (a) is not available</td> </tr> <tr> <td>(c) Regional or national default values</td> <td>For new power plants or if (b) is not available These sources can only be used for liquid fuels and should be based on well-documented, reliable sources (such as national energy balances)</td> </tr> <tr> <td>(d) IPCC default values at the lower limit of the uncertainty at a 95% confidence interval as provided in table 1.4 of chapter 1 of Vol. 2 (Energy) of the 2006 IPCC Guidelines on National GHG Inventories</td> <td>For new power plants or if (c) is not available</td> </tr> </tbody> </table>	Data source	Conditions for using the data source	(a) Values provided by the fuel supplier in invoices	This is the preferred source in case existing plant(s) are identified as the most likely baseline scenario	(b) measurements by the project participants	Applicable to existing captive power plants if (a) is not available	(c) Regional or national default values	For new power plants or if (b) is not available These sources can only be used for liquid fuels and should be based on well-documented, reliable sources (such as national energy balances)	(d) IPCC default values at the lower limit of the uncertainty at a 95% confidence interval as provided in table 1.4 of chapter 1 of Vol. 2 (Energy) of the 2006 IPCC Guidelines on National GHG Inventories	For new power plants or if (c) is not available
Data source	Conditions for using the data source										
(a) Values provided by the fuel supplier in invoices	This is the preferred source in case existing plant(s) are identified as the most likely baseline scenario										
(b) measurements by the project participants	Applicable to existing captive power plants if (a) is not available										
(c) Regional or national default values	For new power plants or if (b) is not available These sources can only be used for liquid fuels and should be based on well-documented, reliable sources (such as national energy balances)										
(d) IPCC default values at the lower limit of the uncertainty at a 95% confidence interval as provided in table 1.4 of chapter 1 of Vol. 2 (Energy) of the 2006 IPCC Guidelines on National GHG Inventories	For new power plants or if (c) is not available										
Measurement procedures (if any):	For (a) and (b): Measurements should be undertaken in line with national or international fuel standards										



Any comment:	For (a): If the fuel supplier does provide the NCV value and the CO ₂ emission factor on the invoice and these two values are based on measurements for this specific fuel, this CO ₂ factor should be used. If another source for the CO ₂ emission factor is used or no CO ₂ emission factor is provided, Options (b), (c) or (d) should be used
--------------	--

Data / Parameter:	$F_{ST,k}$
Data unit:	mass or volume units
Description:	The average annual amount of fuel k used to generate steam at the existing CHP plant during the most recent three years previous to the implementation of the project activity
Source of data:	Project participants
Measurement procedures (if any):	-
Any comment:	-

Data / Parameter:	$F_{ST,NG}$
Data unit:	m ³
Description:	The average annual amount of natural gas used to generate steam during the most recent three years previous to the implementation of the project activity
Source of data:	Project participants
Measurement procedures (if any):	-
Any comment:	-



Data / Parameter:	NCV_k	
Data unit:	TJ/(mass or volume units)	
Description:	Net calorific value of fuel k used to generate steam at the existing CHP plant during the most recent three years previous to the implementation of the project activity	
Source of data:	The following data sources may be used if the relevant conditions apply:	
	Data source	Conditions for using the data source
	Values provided by the fuel supplier of the power plants in invoices	If data is collected from power plant operators (e.g. utilities)
	Regional or national average default values	If values are reliable and documented in regional or national energy statistics / energy balances
	IPCC default values at the lower limit of the uncertainty at a 95% confidence interval as provided in Table 1.2 of Chapter 1 of Vol. 2 (Energy) of the 2006 IPCC Guidelines on National GHG Inventories	If above two data source is not available.
Measurement procedures (if any):	-	
Any comment:	-	



Data / Parameter:	CEF_{BL}										
Data unit:	tCO ₂ /GJ										
Description:	Carbon emission factor of the baseline fuel										
Source of data:	<p>The following data sources may be used if the relevant conditions apply:</p> <table border="1"> <thead> <tr> <th>Data source</th> <th>Conditions for using the data source</th> </tr> </thead> <tbody> <tr> <td>(a) Values provided by the fuel supplier in invoices</td> <td>This is the preferred source in the case of an existing captive power plant</td> </tr> <tr> <td>(b) Measurements by the project participants</td> <td>Applicable to existing captive power plants if (a) is not available</td> </tr> <tr> <td>(c) Regional or national default values</td> <td>For new power plants or if (b) is not available These sources can only be used for liquid fuels and should be based on well-documented, reliable sources (such as national energy balances)</td> </tr> <tr> <td>(d) IPCC default values at the lower limit of the uncertainty at a 95% confidence interval as provided in table 1.4 of Chapter 1 of Vol. 2 (Energy) of the 2006 IPCC Guidelines on National GHG Inventories</td> <td>For new power plants or if (c) is not available</td> </tr> </tbody> </table>	Data source	Conditions for using the data source	(a) Values provided by the fuel supplier in invoices	This is the preferred source in the case of an existing captive power plant	(b) Measurements by the project participants	Applicable to existing captive power plants if (a) is not available	(c) Regional or national default values	For new power plants or if (b) is not available These sources can only be used for liquid fuels and should be based on well-documented, reliable sources (such as national energy balances)	(d) IPCC default values at the lower limit of the uncertainty at a 95% confidence interval as provided in table 1.4 of Chapter 1 of Vol. 2 (Energy) of the 2006 IPCC Guidelines on National GHG Inventories	For new power plants or if (c) is not available
Data source	Conditions for using the data source										
(a) Values provided by the fuel supplier in invoices	This is the preferred source in the case of an existing captive power plant										
(b) Measurements by the project participants	Applicable to existing captive power plants if (a) is not available										
(c) Regional or national default values	For new power plants or if (b) is not available These sources can only be used for liquid fuels and should be based on well-documented, reliable sources (such as national energy balances)										
(d) IPCC default values at the lower limit of the uncertainty at a 95% confidence interval as provided in table 1.4 of Chapter 1 of Vol. 2 (Energy) of the 2006 IPCC Guidelines on National GHG Inventories	For new power plants or if (c) is not available										
Measurement procedures (if any):	For (a) and (b): measurements should be undertaken in line with national or international fuel standards										
Any comment:	For (a): if the fuel supplier does provide the NCV value and the CO ₂ emission factor on the invoice and these two values are based on measurements for this specific fuel, this CO ₂ factor should be used. If another source for the CO ₂ emission factor is used or no CO ₂ emission factor is provided, Options (b), (c) or (d) should be used										

Data / Parameter:	η_{BL}
Data unit:	ratio
Description:	The energy efficiency of the baseline technology
Source of data:	In the case of existing captive power plants, use the latest approved version of the “Tool to determine the baseline efficiency of thermal or electric energy generation systems”. The tool should be used to determine a constant efficiency and not a load-efficiency-function. In the case of new power plants, use the maximum efficiency of the baseline technology at the optimal operating conditions, as supported by the manufacturer of this technology
Measurement procedures (if any):	-
Any comment:	-



Data / Parameter:	GWP_{CH_4}
Data unit:	tCO ₂ e/tCH ₄
Description:	Global warming potential of methane valid for the relevant commitment period
Source of data:	Default value of 21 for the first commitment period under the Kyoto Protocol
Measurement procedures (if any):	-
Any comment:	-

Data / Parameter:	$EF_{NG,upstream,CH_4}$
Data unit:	tCH ₄ /TJ
Description:	Emission factor for upstream fugitive methane emissions of natural gas from production, transportation, distribution, and, in the case of LNG, liquefaction, transportation, re-gasification and compression into a transmission or distribution system
Source of data:	Where reliable and accurate national data on fugitive CH ₄ emissions associated with the production, and in case of natural gas, the transportation and distribution of the fuels is available, project participants should use this data to determine average emission factors by dividing the total quantity of CH ₄ emissions by the quantity of fuel produced or supplied respectively. Where such data is not available, project participants should use the default values provided in the Table 2 in the baseline methodology
Measurement procedures (if any):	-
Any comment:	-

Data / Parameter:	$EF_{k,upstream,CH_4}$
Data unit:	tCH ₄ /TJ
Description:	Emission factor for upstream fugitive methane emissions from production of the fuel type k (a coal or oil type)
Source of data:	Where reliable and accurate national data on fugitive CH ₄ emissions associated with the production, and in case of natural gas, the transportation and distribution of the fuels is available, project participants should use this data to determine average emission factors by dividing the total quantity of CH ₄ emissions by the quantity of fuel produced or supplied respectively. Where such data is not available, project participants should use the default values provided in the Table 2 in the baseline methodology
Measurement procedures (if any):	-
Any comment:	-



Data / Parameter:	$EF_{CO_2,upstream,LNG}$
Data unit:	tCO ₂ e/TJ
Description:	Emission factor for upstream CO ₂ emissions due to fossil fuel combustion/electricity consumption associated with the liquefaction, transportation, re-gasification and compression of LNG into a natural gas transmission or distribution system
Source of data:	Where reliable and accurate data on upstream CO ₂ emissions due to fossil fuel combustion/electricity consumption associated with the liquefaction, transportation, re-gasification and compression of LNG into a natural gas transmission or distribution system is available, project participants should use this data to determine an average emission factor. Where such data is not available, project participants may assume a default value of 6 tCO ₂ e/TJ as a rough approximation
Measurement procedures (if any):	-
Any comment:	-

Data / Parameter:	r_{CO_2}
Data unit:	Ratio
Description:	Average CO ₂ content in the raw natural gas stream on volume basis
Source of data:	Official, governmental or public studies; public databases; or written statements from the applicable natural gas processing facility(ies), including the average chemical composition of the raw gas in the reservoirs where the project activity natural gas is extracted from
Measurement procedures (if any):	-
Any comment:	-

Data / Parameter:	ρ_{CO_2}
Data unit:	tonnes/m ³
Description:	Density of the CO ₂ under standard conditions
Source of data:	A default value of 0.001978 tCO ₂ / m ³ CO ₂ under standard conditions
Measurement procedures (if any):	-
Any comment:	-

III. MONITORING METHODOLOGY

All monitoring should be attended to by appropriate and adequate personnel, as assessed by the project participants. All data collected as part of the monitoring should be archived electronically and be kept at least for two years after the end of the last crediting period. 100% of the data should be monitored if not indicated otherwise in the tables below. All measurements should be conducted with calibrated measurement equipment according to relevant industry standards. In addition, the monitoring provisions in the tools referred to in this methodology apply.

Describe and specify in the CDM-PDD all monitoring procedures, including the type of measurement instrumentation used, the responsibilities for monitoring and QA/QC procedures that will be applied. Where the methodology provides different options (e.g. use of default values or on-site measurements),



specify which option will be used. All meters and instruments should be calibrated regularly as per industry practices.

All data collected as part of monitoring should be archived electronically and be kept at least for 2 years after the end of the last crediting period. 100% of the data should be monitored if not indicated otherwise in the tables below. All measurements should be conducted with calibrated measurement equipment according to relevant industry standards.

In addition, the monitoring provisions in the tools referred to in this methodology apply. Accordingly, the parameters $j, i, FF_{j,k,y}, FF_{i,k,y}, NCV_{j,k,y}, NCV_{i,k,y}, EG_{j,y}, EG_{i,y}$, should be determined as per the “Tool to calculate the emission factor for an electricity system”.

The operation of the existing boilers, including their fuel consumption, steam and electricity generation, is monitored in order to confirm that the output level of the existing CHP plant is not influenced by the operation of the project gas turbine generator, but by heat demand and/or baseload electricity demand which the plant has to meet.

The exact monitoring procedure for the output level of the existing CHP plant should be developed on a case by case basis taking into consideration the local regulations and plant-specific conditions. One option is to limit the monitoring procedure only to an official confirmation by the relevant power regulatory authorities that the heat supply from the existing CHP plant is demand-driven and that the existing CHP plant supplies baseload electricity.

Data and parameters monitored

Data / Parameter:	$EG_{PJ,GT,y}$
Data unit:	MWh
Description:	Quantity of electricity generated by the gas turbine that is fed into the grid and/or supplied to the electricity consuming facility in year y
Source of data:	Onsite measurement by project participants
Measurement procedures (if any):	Use electricity meters installed at the grid interface for electricity export to grid and for supply to captive consumers use electricity meters installed at the entrance of the electricity consuming facility (battery limits)
Monitoring frequency:	Continuously, aggregated at least annually
QA/QC procedures:	Cross check measurement results with records for sold electricity
Any comment:	-

Data / Parameter:	$SG_{PJ,HRSG,y}$
Data unit:	TJ
Description:	Steam generated by the project facility from heat recovery steam generator (HRSG) in year y
Source of data:	Onsite measurement by project participants
Measurement procedures (if any):	-
Monitoring frequency:	Continuously, aggregated at least annually
QA/QC procedures:	As per internal QA/QC procedures of the plant
Any comment:	-



Data / Parameter:	$F_{NG,GT,y}$
Data unit:	m ³
Description:	Natural gas consumption by the project gas turbine generator in year <i>y</i>
Source of data to be used:	Onsite measurement by project participants
Measurement procedures (if any)	Use volume meters.
Monitoring frequency:	Continuously, aggregated at least annually
QA/QC procedures to be applied:	The consistency of metered fuel consumption quantities should be cross-checked by an annual energy balance that is based on purchased quantities and stock changes
Any comment:	-

Data / Parameter:	$NCV_{k,y}$										
Data unit:	TJ/mass or volume units										
Description:	Net calorific value of fuel <i>k</i> in year <i>y</i>										
Source of data to be used:	<p>The following data sources may be used if the relevant conditions apply:</p> <table border="1"> <thead> <tr> <th>Data source</th> <th>Conditions for using the data source</th> </tr> </thead> <tbody> <tr> <td>a) Values provided by the fuel supplier in invoices</td> <td>This is the preferred source</td> </tr> <tr> <td>b) Measurements by the project participants</td> <td>If a) is not available</td> </tr> <tr> <td>c) Regional or national default values</td> <td>If b) is not available These sources can only be used for liquid fuels and should be based on well documented, reliable sources (such as national energy balances)</td> </tr> <tr> <td>d) IPCC default values at the lower limit of the uncertainty at a 95% confidence interval as provided in Table 1.2 of Chapter 1 of Vol. 2 (Energy) of the 2006 IPCC Guidelines on National GHG Inventories</td> <td>If c) is not available</td> </tr> </tbody> </table>	Data source	Conditions for using the data source	a) Values provided by the fuel supplier in invoices	This is the preferred source	b) Measurements by the project participants	If a) is not available	c) Regional or national default values	If b) is not available These sources can only be used for liquid fuels and should be based on well documented, reliable sources (such as national energy balances)	d) IPCC default values at the lower limit of the uncertainty at a 95% confidence interval as provided in Table 1.2 of Chapter 1 of Vol. 2 (Energy) of the 2006 IPCC Guidelines on National GHG Inventories	If c) is not available
Data source	Conditions for using the data source										
a) Values provided by the fuel supplier in invoices	This is the preferred source										
b) Measurements by the project participants	If a) is not available										
c) Regional or national default values	If b) is not available These sources can only be used for liquid fuels and should be based on well documented, reliable sources (such as national energy balances)										
d) IPCC default values at the lower limit of the uncertainty at a 95% confidence interval as provided in Table 1.2 of Chapter 1 of Vol. 2 (Energy) of the 2006 IPCC Guidelines on National GHG Inventories	If c) is not available										
Measurement procedures (if any)	For a) and b): Measurements should be undertaken in line with national or international fuel standards										
Monitoring frequency:	For a) and b): The NCV should be obtained for each fuel delivery, from which weighted average annual values should be calculated For c): Review appropriateness of the values annually For d): Any future revision of the IPCC Guidelines should be taken into account										



QA/QC procedures to be applied:	Verify if the values under a), b) and c) are within the uncertainty range of the IPCC default values as provided in Table 1.2, Vol. 2 of the 2006 IPCC Guidelines. If the values fall below this range collect additional information from the testing laboratory to justify the outcome or conduct additional measurements. The laboratories in a), b) or c) should have ISO17025 accreditation or justify that they can comply with similar quality standards
Any comment:	-

Data / Parameter:	$NCV_{NG,y}$	
Data unit:	TJ/m ³	
Description:	Average net calorific value of natural gas combusted in year <i>y</i>	
Source of data to be used:	The following data sources may be used if the relevant conditions apply:	
	Data source	Conditions for using the data source
	a) Values provided by the fuel supplier in invoices	This is the preferred source
	b) Measurements by the project participants	If a) is not available
	c) Regional or national default values	If b) is not available These sources can only be used for liquid fuels and should be based on well documented, reliable sources (such as national energy balances).
	d) IPCC default values at the lower limit of the uncertainty at a 95% confidence interval as provided in Table 1.2 of Chapter 1 of Vol. 2 (Energy) of the 2006 IPCC Guidelines on National GHG Inventories	If c) is not available
Measurement procedures (if any)	For a) and b): Measurements should be undertaken in line with national or international fuel standards	
Monitoring frequency:	For a) and b): The NCV should be obtained for each fuel delivery, from which weighted average annual values should be calculated For c): Review appropriateness of the values annually For d): Any future revision of the IPCC Guidelines should be taken into account	
QA/QC procedures to be applied:	Verify if the values under a), b) and c) are within the uncertainty range of the IPCC default values as provided in Table 1.2, Vol. 2 of the 2006 IPCC Guidelines. If the values fall below this range collect additional information from the testing laboratory to justify the outcome or conduct additional measurements. The laboratories in a), b) or c) should have ISO17025 accreditation or justify that they can comply with similar quality standards	
Any comment:	-	

Data / Parameter:	$SG_{PJ,SB,y}$
Data unit:	TJ
Description:	Steam generated in the project scenario by the existing steam boilers in year <i>y</i>



Source of data to be used:	On-site measurement by project participants
Measurement procedures (if any):	-
Monitoring frequency:	Continuously, aggregated at least annually



QA/QC procedures to be applied:	-
Any comment:	This parameter is used for confirming the operation of the existing boilers after the project implementation, as well as for calculating the project emissions

Data / Parameter:	$F_{k,SB,y}$
Data unit:	mass or volume units
Description:	The amount of fossil fuel k consumed by the existing steam boilers in year y
Source of data to be used:	Onsite measurement by project participants
Measurement procedures (if any):	-
Monitoring frequency:	Continuously, aggregated at least annually
QA/QC procedures to be applied:	-
Any comment:	-

Data / Parameter:	$F_{NG,SB,y}$
Data unit:	mass or volume units
Description:	Natural gas consumption by the existing steam boilers in year y
Source of data to be used:	Onsite measurement by project participants
Measurement procedures (if any):	-
Monitoring frequency:	Continuously, aggregated at least annually
QA/QC procedures to be applied:	-
Any comment:	-

Data / Parameter:	$EG_{PJ,STG,y}$
Data unit:	MWh
Description:	Total electricity supplied to the grid by the existing steam turbine generator (STG) at the project site in year y
Source of data to be used:	Onsite measurement by project participants
Measurement procedures (if any):	-
Monitoring frequency:	Continuously, aggregated at least annually
QA/QC procedures to be applied:	Cross check measurement results with records for sold electricity
Any comment:	This parameter is used for monitoring and confirming the operation of the existing steam turbine



IV. REFERENCES AND ANY OTHER INFORMATION

Not applicable.

History of the document

Version	Date	Nature of revision(s)
01.0.0	EB 65, Annex 07 25 November 2011	Initial adoption.
Decision Class: Regulatory Document Type: Standard Business Function: Methodology		